



# THREE-PHASE HYBRID INVERTER



## USER MANUAL

SYNK-8K-SG04LP3  
SYNK-10K-SG04LP3  
SYNK-12K-SG04LP3

[www.sunsynk.com](http://www.sunsynk.com)  
[sales@sunsynk.com](mailto:sales@sunsynk.com)  
[customerservices@sunsynk.com](mailto:customerservices@sunsynk.com)

v.38 (08/05/24)

 **PLEASE RETAIN FOR  
FUTURE REFERENCE**

# PREFACE

This User Manual contains information for proper installation, operation, maintenance, and care of the Sunsynk Three-Phase Hybrid Inverter. A deep understanding of the instructions described in this document will help you get the most out of your new inverter.

This document should be read thoroughly, and all the procedures described in this manual should be followed carefully. If you have questions or concerns about this product's operation and maintenance, please get in touch with our customer support.

All personnel involved in this machine's installation, setup, operation, maintenance, and repair should read and understand this manual, mainly its safety instructions. Substandard performance and longevity, property damage, and personal injury may result from not knowing and following these instructions.

In order to ensure long product life, Sunsynk recommends that you utilize the product and perform maintenance by correctly following the instructions described in this guide. The manufacturer's warranty does not cover any damage resulting from the neglect of these instructions.

Sunsynk assumes no liability for damage caused by the operation contrary to what is specified in this operating manual.

All information in this User Manual is based on the latest product information available at the time of printing approval. Sunsynk reserves the right to make changes at any time without notice and without incurring any obligation.

Please always keep this manual with the inverter as a reference for everyone using this product.

# Table of Contents

|   |           |   |           |
|---|-----------|---|-----------|
| <b>SAFETY</b>                           | <b>4</b>  | Basic Setup                             | 38        |
| General Safety                          | 4         | Set Time (Clock)                        | 38        |
| Symbols/Safety Signs                    | 4         | Set Company Name / Beeper / Auto dim    | 38        |
| Safety Instructions                     | 6         | Factory Reset and Lock Code             | 39        |
| Product Disposal                        | 6         | Inverter Remote Control                 | 40        |
|   |           | Battery Setup Page                      | 40        |
| <b>PRODUCT INTRODUCTION</b>             | <b>7</b>  | Generator & Battery Page                | 41        |
| System Overview                         | 7         | Battery Discharge Page                  | 43        |
| Product Size                            | 8         | Setting Up a Lithium Battery            | 45        |
| Product Features                        | 9         | Program Charge & Discharge Times        | 52        |
| Basic System Architecture               | 10        | Grid Supply Page                        | 55        |
|   |           | Paralleling Inverters Advanced Settings | 58        |
| <b>TECHNICAL SPECIFICATIONS</b>         | <b>11</b> | Connecting the DRM's                    | 60        |
|   |           | Solar Power Generated                   | 61        |
|   |           | Grid Power                              | 62        |
| <b>INSTALLATION</b>                     | <b>13</b> | Advanced Settings for Wind Turbines     | 62        |
| Parts List                              | 13        | Advanced Settings for Auxiliary Load    | 63        |
| Selecting the Mounting Area             | 14        |   |           |
| Mounting the Inverter                   | 15        | <b>OPERATION MODES</b>                  | <b>65</b> |
| Battery Connection                      | 17        | Mode I: Basic                           | 65        |
| Function Port Definition                | 18        | Mode II: With Generator                 | 65        |
| Lead-Acid Battery Temperature Sensor    | 19        | Mode III: With Aux-Load                 | 65        |
| AC and Backup Load Connection           | 20        | Mode IV: AC Couple                      | 66        |
| PV Connection                           | 22        | Mode V: Grid-Tied                       | 66        |
| PV Module Selection                     | 22        |   |           |
| PV Module Wiring                        | 22        | <b>FAULT CODES</b>                      | <b>67</b> |
| Connecting the CT Coil                  | 24        |   |           |
| Meter Connection                        | 25        | <b>COMMISSIONING</b>                    | <b>71</b> |
| CHiNT Meter                             | 25        | Start-Up / Shutdown Procedure           | 71        |
| Eastron Meter                           | 25        | Inverter Commissioning Info             | 72        |
| Earth Connection (MANDATORY)            | 26        | GDFI Fault                              | 72        |
| Wiring System for Inverter              | 28        |   |           |
| Wiring Diagram                          | 29        | <b>MAINTENANCE</b>                      | <b>72</b> |
| Typical Application of Diesel Generator | 31        |   |           |
| Three Phase Parallel Connection         | 32        | <b>APPENDIX A</b>                       | <b>73</b> |
|   |           | <b>APPENDIX B</b>                       | <b>74</b> |
| <b>OPERATION</b>                        | <b>33</b> | <b>APPENDIX C</b>                       | <b>74</b> |
| Switching ON/OFF                        | 33        | <b>APPENDIX D</b>                       | <b>74</b> |
| Display                                 | 33        | <b>APPENDIX E</b>                       | <b>74</b> |
| LED Indicators                          | 33        |   |           |
| Function Buttons                        | 33        |   |           |
| LCD Operation Flow Chart                | 34        |   |           |
| Home Page                               | 35        |   |           |
| Status Page                             | 35        |   |           |
| System Flow Page                        | 36        |   |           |
| Setup Page                              | 37        |   |           |

# SAFETY

## General Safety

- This device should only be used in accordance with the instructions within this manual and in compliance with local, regional, and national laws and regulations. Only allow this device to be installed, operated, maintained, and repaired by other people who have read and understood this manual. Ensure the manual is included with this device should it be passed to a third party.
- DO NOT allow minors, untrained personnel, or person(s) suffering from a physical or mental impairment that would affect their ability to follow this manual, install, maintain or repair this device.
- Any untrained personnel who might get near this device while it is in operation MUST be informed that it is dangerous and instructed carefully on how to avoid injury.

## Symbols/Safety Signs

|   |   |   |   |
|---|---|---|---|
|    | <p>This symbol indicates information that if ignored, could result in personal injury, physical damage or even death due to incorrect handling.</p> |    | <p>CE mark is attached to the solar inverter to verify that the unit follows the provisions of the European Low Voltage and EMC Directives.</p>   |
|   | <p>Risk of burn.</p>  |   | <p>Keep the equipment well-ventilated.</p>  |
|  | <p>Risk of electric shock.<br/>DO NOT touch the terminal or remove the shell within 5 minutes after disconnecting all power.</p>                    |  | <p>The UKCA marking is used for products placed on the market in Great Britain (England, Scotland and Wales). The UKCA marking applies to most products for which the CE marking could be used.</p> |
|  | <p>This product's batteries contain an explosive, self-reactive material that could blow up when heated.</p>  |  | <p>Do not disassemble or alter the battery in any way. Do not strike or puncture the battery.</p>   |
|  | <p>The Battery is heavy and can cause injury if not handled safely.</p>   |  | <p>ONLY qualified personnel should install or perform maintenance work on the units.</p>  |
|  | <p>Be careful when touching the inverter! It is an electrical product with risk of electric shock and heating.</p>                                  |  | <p>Warranty Void if Seal is Broken.</p>   |
|  | <p>Do not place near open fire or incinerate. Do not use near heaters or hot temperature sources.</p>   |  | <p>Keep the product out of reach of children!</p>   |
|  | <p>Do not stand on.</p>   |  | <p>Avoid unsuitable shoes for installing and operating the inverter.</p>  |
|  | <p>Do not step or put any objects onto the battery.</p>   |  | <p>Do not drop, deform, or impact the battery.</p>  |

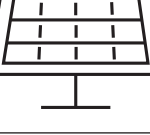
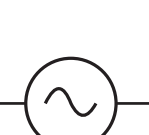
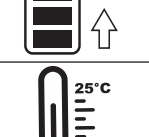
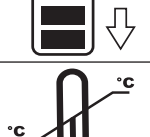
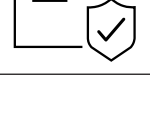
|   |  |   |   |
|---|--|---|---|
|    | Single Phase.  |    | Three Phase.  |
|    | Protective Conductor Terminal or Earth Ground Terminal.  |    | Rechargeable.   |
|    | Do not submerge the battery in water or expose it to moisture or liquid.   |    | Keep out of reach of children, animals, and insects.  |
|    | Do not expose the product to sunlight.   |    | Inverter DC to AC.  |
|    | Li-ion Battery.  |    | Net Weight in Kilograms.  |
|   | <b>BATTERY INPUT</b><br>Battery Discharge Voltage, Battery Discharge Current, Input Voltage Type, Battery Discharge Power.   |   | <b>PV INPUT</b><br>PV Input Voltage, Number of MPPT's, MPPT Input Current & Max PV ISC.   |
|  | Direct Current.  |  | Indicates that this product is recyclable.  |
|  | <b>AC OUTPUT</b><br>Output Voltage, Input Voltage Type, Ac Output Rated Current, Max AC Current, Output Frequency, Max AC ISC, Power Factor & AC Output Rated Power. |  | <b>CONTINUOUS OUTPUT CURRENT</b><br>Maximum Continuous Output Current, Output Frequency and Voltage, & AUX (programmable AC output on battery SOC).   |
|  | Charging.  |  | Discharging.  |
|  | Follow the indicated temperatures.   |  | <b>TEMPERATURE</b><br>Ambient, Min & Max.   |
|  | <b>MANUAL DOWNLOAD</b><br>Download the latest version of the instruction manual by scanning the QR code.   |  | <b>WARRANTY REGISTRATION</b><br>Scan the QR code to access our website and sign up for the manufacturer's warranty.   |
|  | Do not dispose the device, accessories, and packaging with regular waste. Follow local ordinances or contact the manufacturer for disposal guidance.                 |  | Refer to the operating instructions. Contact the supplier within 24 hours if there is anything wrong. In case of leakage contact with eyes or skin, immediately clean with water and seek help from a doctor. |

# Safety Instructions



## WARNING

### HIGH LIFE RISK DUE TO FIRE OR ELECTROCUTION.

Sunsynk Three-Phase Hybrid Inverter can only be installed by a qualified licensed electrical contractor. This is not a DIY product.

- This chapter contains important safety and operating instructions. Read and keep this manual for future reference.
- Before using the inverter, please read the instructions and warning signs of the battery and corresponding sections in the instruction manual.
- Do not disassemble the inverter. If you need maintenance or repair, take it to a professional service center.
- Improper reassembly may result in electric shock or fire.
- To reduce risk of electric shock, disconnect all wires before attempting any maintenance or cleaning.
- Turning off the unit will not reduce this risk.
- Never charge a frozen battery.
- For optimum operation of this inverter, please follow required specification to select appropriate cable size. It is very important to correctly operate this inverter.
- Be very cautious when working with metal tools on or around batteries. Dropping a tool may cause a spark or short circuit in batteries or other electrical parts, even cause an explosion.
- Please strictly follow installation procedure when you want to disconnect AC or DC terminals.
- Please refer to "Installation" section of this manual for the details.
- Grounding instructions - this inverter should be connected to a permanent grounded wiring system. Be sure to comply with local requirements and regulation to install this inverter.
- Never cause AC output and DC input short circuited. Do not connect to the mains when DC input short circuits.

## Product Disposal

### DO NOT dispose this product with domestic waste!

Electrical devices should be disposed of in accordance with regional directives on electronic and/ or electronic-waste disposal. In case of further questions, please consult your supplier. In some cases, the supplier can take care of proper disposal.

# PRODUCT INTRODUCTION

The Sunsynk Three-Phase Hybrid Inverter is a multifunctional inverter, combining functions of inverter, solar charger and battery charger to offer uninterruptible power support with portable size. Its comprehensive LCD display offers user configurable and easy accessible button operation such as battery charging, AC/solar charging, and acceptable input voltage based on different applications.

## System Overview

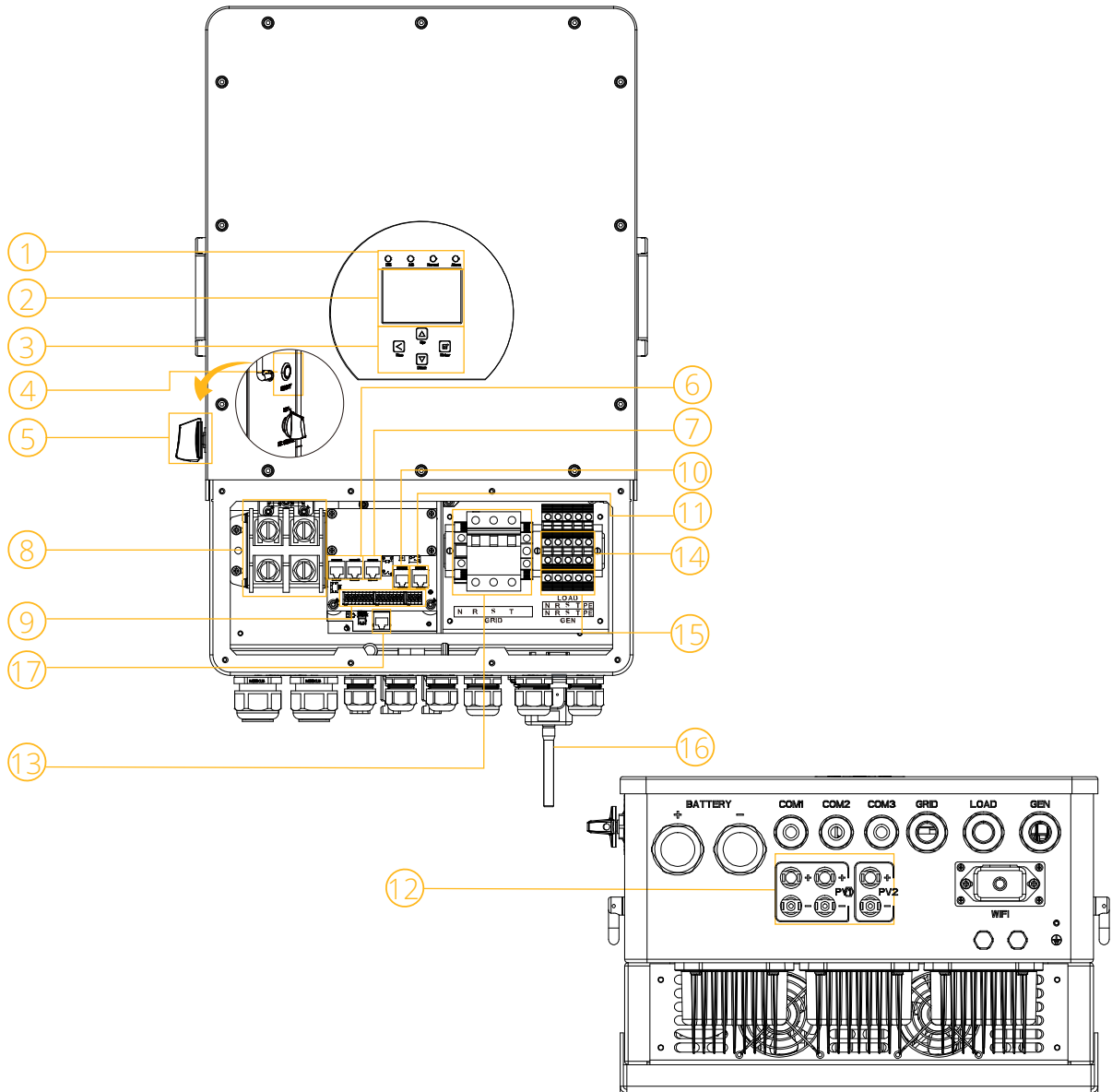

- 1. Inverter Indicators
- 2. LCD Display
- 3. Function Buttons
- 4. Power On/Off Button
- 5. DC Switch
- 6. Parallel Port

- 7. Meter-485 Port
- 8. Battery Input Connectors
- 9. Function Port
- 10. Modbus Port
- 11. BMS Port
- 12. PV Input with Two MPPT

- 13. Grid
- 14. Load
- 15. Generator Input
- 16. Wi-Fi Interface
- 17. DRM Port

# Product Size

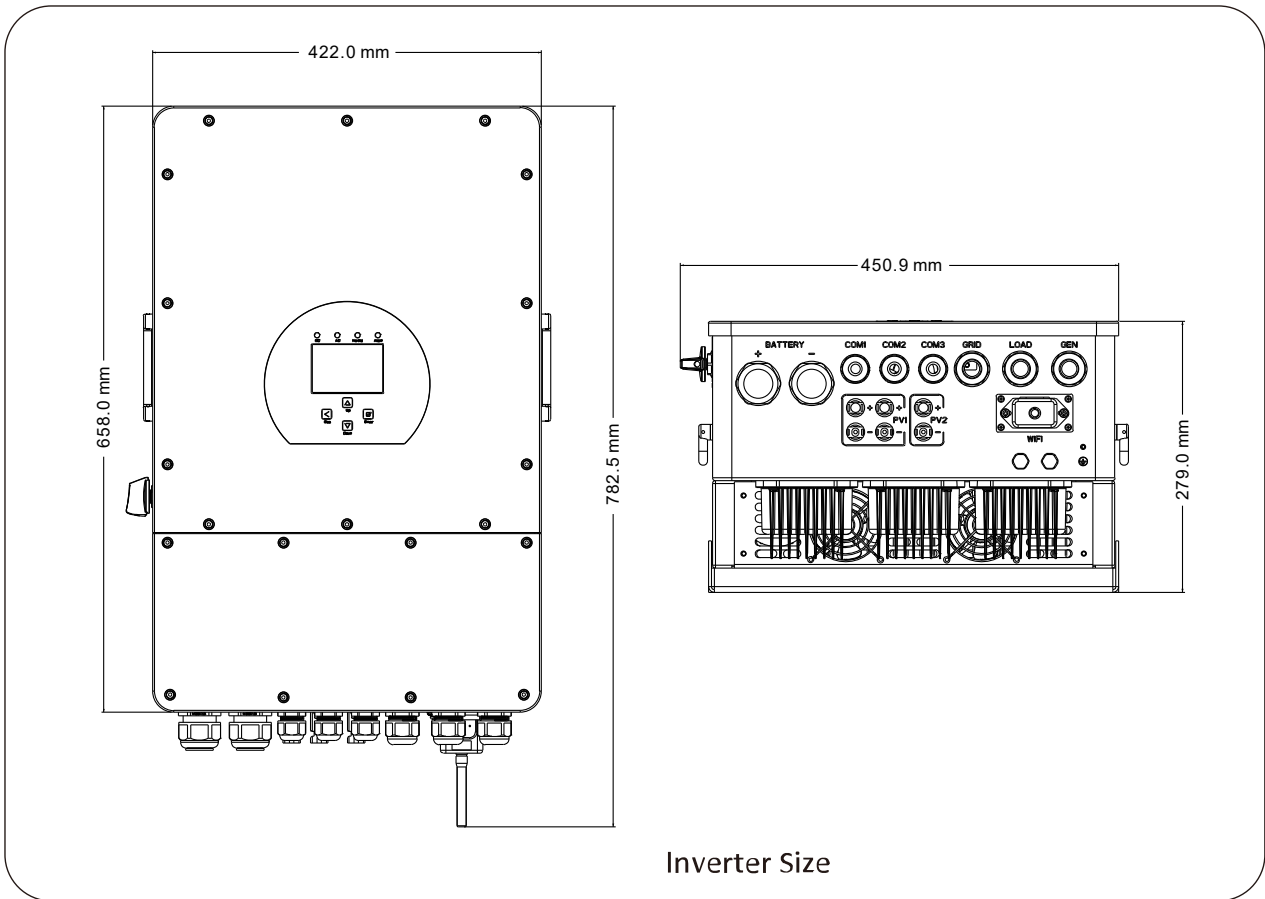

Inverter Size

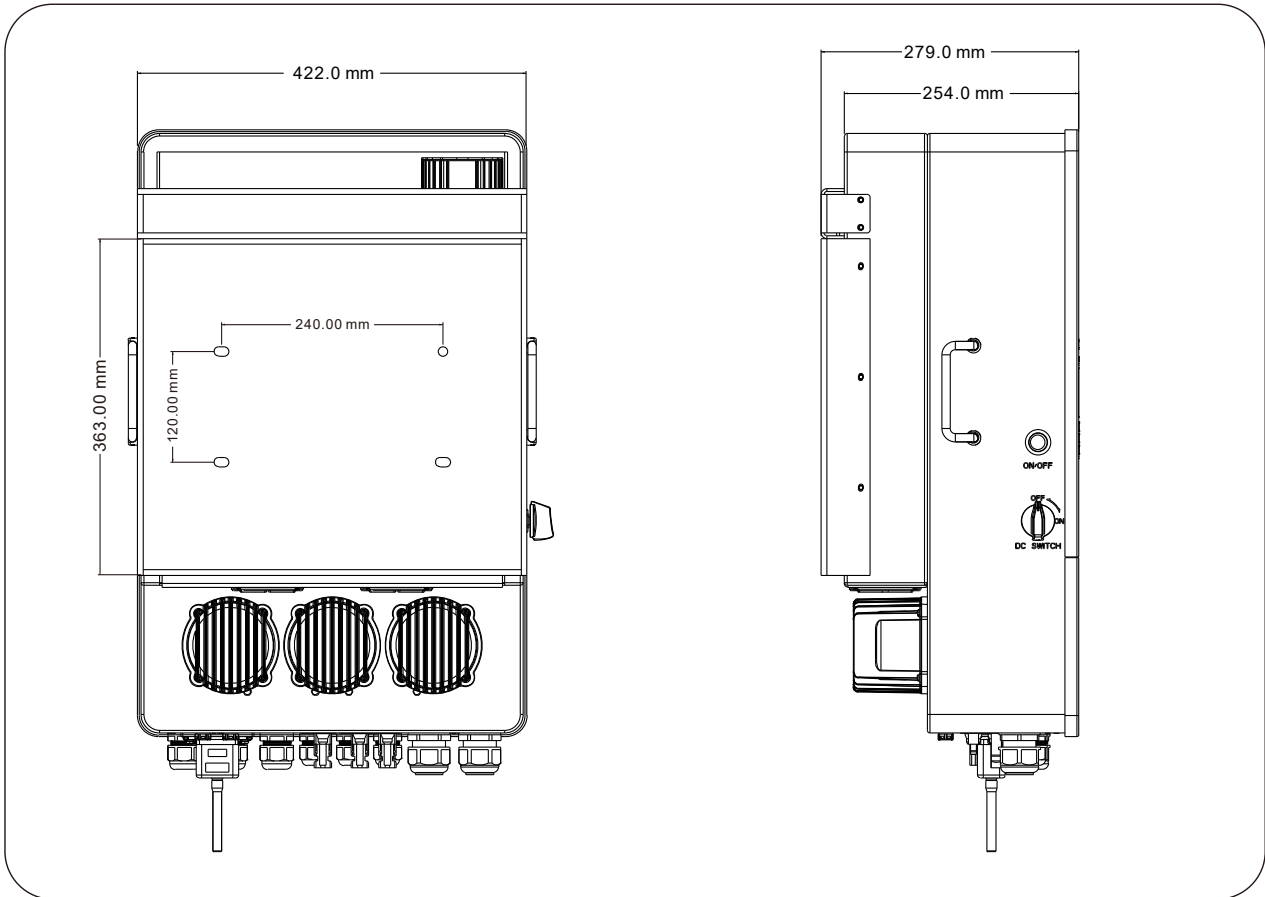



# Product Features

## INTERACTIVE

- Easy and straightforward to understand LCD display;
- Supporting Wi-Fi or GSM monitoring;
- Visual power flow screen;
- Built-in 2 strings for 1 MPP tracker and 1 string for 1 MPP tracker;
- Smart settable 3-stage MPPT charging for optimised battery performance;
- Auxiliary load function;
- Multi-inverter function: grid-tied and off-grid;

## COMPATIBLE

- Compatible with mains electrical grid voltages or power generators;
- Compatible with wind turbines;
- 230V/400V Three-phase Pure Sine-wave Inverter;
- It can power up both single-phase and 3-phase loads;
- Self-consumption and feed-in to the grid;
- Auto restart while AC is recovering;
- Maximum charging/discharging current of 190A (8kW), 210A (10kW), and 240A (12kW);
- DC and AC coupled to retrofit existing solar system;
- Compatible with a 48V low-voltage battery;

## CONFIGURABLE

- Fully programmable controller;
- Programmable supply priority for battery or grid;
- Programmable multiple operation modes: on-grid/off-grid & UPS;
- Configurable battery charging - current/voltage based on applications by LCD setting;
- Configurable AC / solar / generator charger priority by LCD setting;
- 6 time periods for battery charging/discharging;

## SECURE

- Overload/over-temperature/short-circuit protection;
- Smart battery charger design for optimised battery protection;
- Limiting function installed to prevent excess power overflow to the grid;
- Isolation transformer design;

## APPLICATIONS

- Marine (vessel power management);
- Power shedding (home/office/factory);
- UPS (fuel-saving systems);
- Remote locations with solar and wind generators;
- Building sites;
- Telecommunication;

# Basic System Architecture

The following diagram explains the basic application and architecture of this 3-Phase Inverter.

It also includes the following devices to have a Complete running system.

- Generator or Utility
- PV modules
- Batteries
- Normal and smart loads
- Monitoring system

Consult with your system integrator for other possible system architectures depending on your requirements.

This inverter can power all kinds of appliances in the home or one environment, including motor-type appliances such as refrigerators and air conditioners.

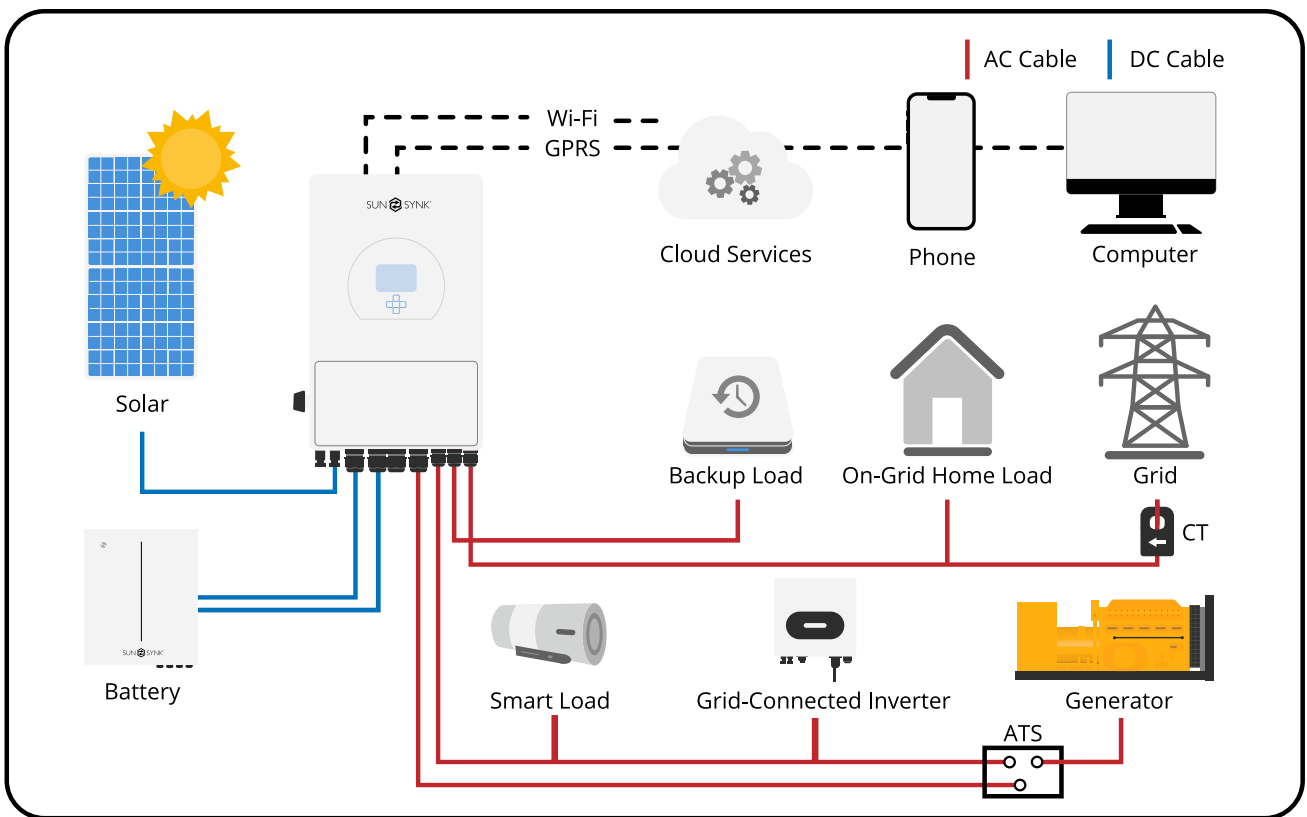

# TECHNICAL SPECIFICATIONS

| Model                                      | SYNK-8K-SG04LP3   | SYNK-10K-SG04LP3 | SYNK-12K-SG04LP3 |
|--|---|------------------|------------------|
| <b>Battery Input Data</b>                  |   |                  |                  |
| Battery Type                               | Lead-acid or Li-Ion   |                  |                  |
| Battery Voltage Range                      | 40Vd.c ~ 60Vd.c   |                  |                  |
| Max. Charging/Discharging Current          | 190Ad.c (max.)  | 210Ad.c (max.)   | 240Ad.c (max.)   |
| Charging Curve                             | 3 Stages / Equalization   |                  |                  |
| External Temperature Sensor                | Yes   |                  |                  |
| Charging Strategy for Li-Ion Battery       | Self-adaption to BMS  |                  |                  |
| <b>PV String Input Data</b>                |   |                  |                  |
| Max. DC Input Power                        | 10400W  | 13000W           | 15600W           |
| PV Input Voltage                           | 550Vd.c (160Vd.c ~ 800Vd.c)   |                  |                  |
| MPPT Range                                 | 200Vd.c ~ 650Vd.c   |                  |                  |
| Start-up Voltage                           | 160V  |                  |                  |
| PV Input Current                           | 13Ad.c + 13Ad.c   | 26Ad.c + 13Ad.c  |                  |
| Max. PV Isc                                | 17Ad.c + 17Ad.c   | 34Ad.c + 17Ad.c  |                  |
| No. of MPPT Trackers                       | 2   |                  |                  |
| No. of Strings Per MPPT Tracker            | 1+1   | 2+1              |                  |
| <b>AC Output Data</b>                      |   |                  |                  |
| Rated AC Output and UPS Power              | 8000W   | 10000W           | 12000W           |
| Max. AC Output Power                       | 8800W   | 11000W           | 13200W           |
| Peak Power (Off-Grid)                      | 2 times of rated power, 10 S  |                  |                  |
| AC Output Rated Current                    | 12.1/11.6A  | 15.2/14.5A       | 18.2/17.4A       |
| Max. AC Current                            | 13.4/12.8A  | 16.7/15.9A       | 20/19.1A         |
| Max. Three-phase Unbalanced Output Current | 18.2/17.4A  | 22.7/21.7A       | 27.3/26.1A       |
| Max. Output Short Circuit Current          | 75A   |                  |                  |
| Max. Continuous AC Passthrough             | 45A   |                  |                  |
| Output Frequency and Voltage               | 50/60Hz;3L/N/PE 220/380, 230/400Vac (Three phase)   |                  |                  |
| Grid Type                                  | Three phase   |                  |                  |
| Total Harmonic Distortion (THD)            | <3% (of nominal power)  |                  |                  |
| DC Current Injection                       | <0.5% In  |                  |                  |
| <b>Efficiency</b>                          |   |                  |                  |
| Max. Efficiency                            | 97.60%  |                  |                  |
| Euro Efficiency                            | 97.00%  |                  |                  |
| MPPT Efficiency                            | >99%  |                  |                  |
| <b>Protection</b>                          |   |                  |                  |
| Integrated                                 | PV Arc Fault Detection, PV Input Lightning Protection, Anti-islanding Protection, PV String Input Reverse Polarity Protection, Insulation Resistor Detection, Residual Current Monitoring Unit, Output Over Current Protection, Output Shorted Protection |                  |                  |
| Surge Protection                           | TYPE II(DC), TYPE II(AC)  |                  |                  |
| Over Voltage Category                      | OVC II(DC), OVC III(AC)   |                  |                  |

## Certifications and Standards

|                       |   |
|-----------------------|---|
| Grid Regulation       | EN 50549-1, AS-NZS 4777.2, NRS 097-2-1; Additional connections available upon request |
| EMC/Safety Regulation | IEC/EN 61000-6-1/2/3/4, IEC/EN 62109-1, IEC/EN 62109-2                                |

## General Data

|                             |  |
|-----------------------------|--|
| Operating Temperature Range | -40 to +60 °C, >45 °C Derating                     |
| Cooling                     | Intelligent Air Cooling                            |
| Noise                       | ≤45 dB   |
| Communication with BMS      | RS485; CAN   |
| Net Weight                  | 38.5kg   |
| Gross Weight                | 47.5kg   |
| Cabinet Size                | 422W×702H×281D (Excluding connectors and brackets) |
| Protection Degree           | IP65   |
| Installation Style          | Wall-mounted                                       |
| Warranty                    | 5 Years  |



### NOTE:

#### Safe Transport and Handling of Inverter:

When transporting the equipment, use its original packaging and keep it as a complete unit. Store the product in a dry environment, avoiding direct sunlight, and maintain a temperature range between -40°C and 60°C. Since the equipment can be quite heavy, always consider its total weight when moving, transporting, or installing it, ensuring that the installation site has adequate load-bearing capacity. Transporting and installing the inverter should be carried out solely by qualified personnel.

# INSTALLATION

## Parts List

Check the equipment before installation. Please make sure nothing is damaged in the package. You should have received the items in the following package:

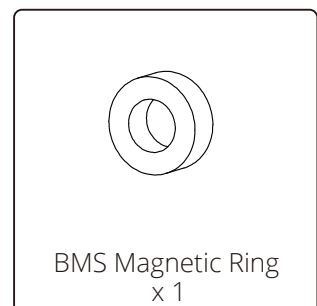
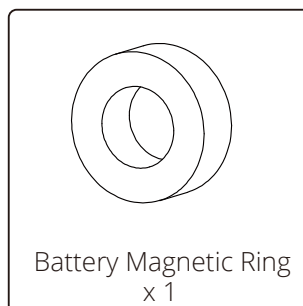
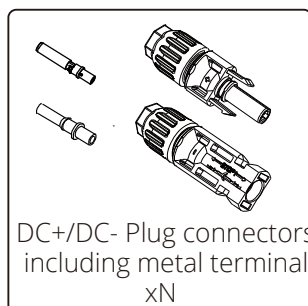
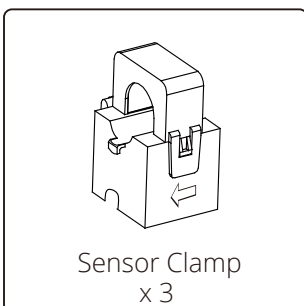
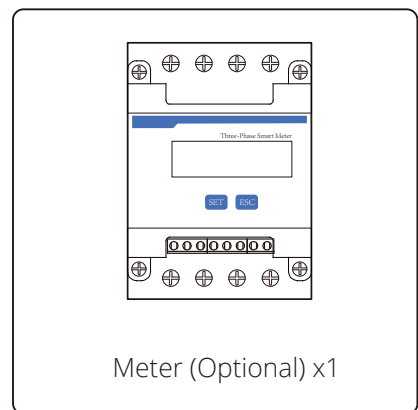
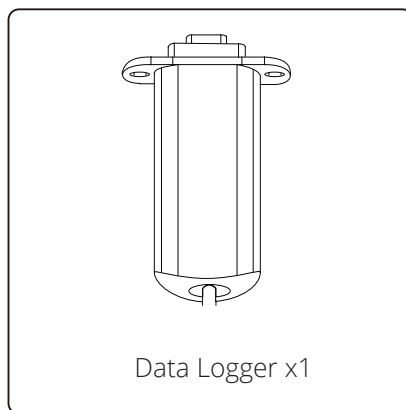
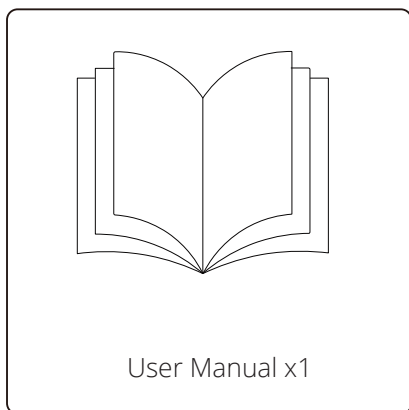
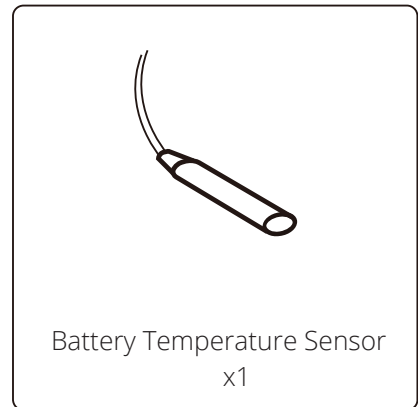
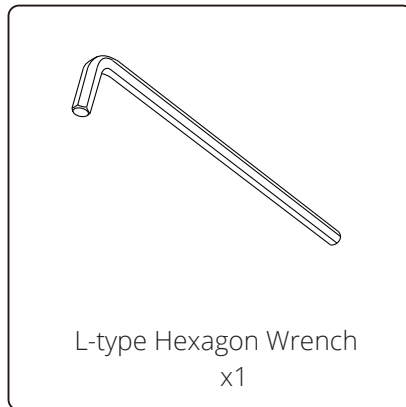
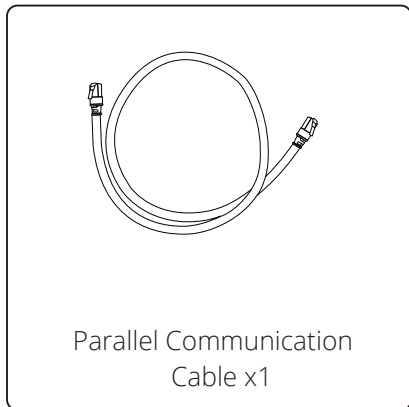
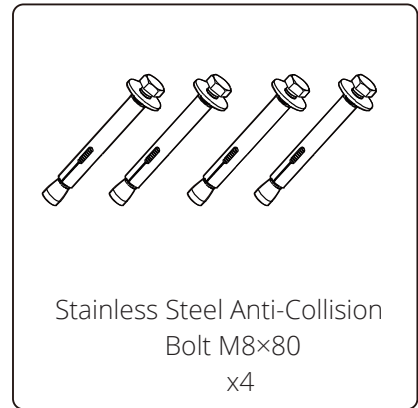
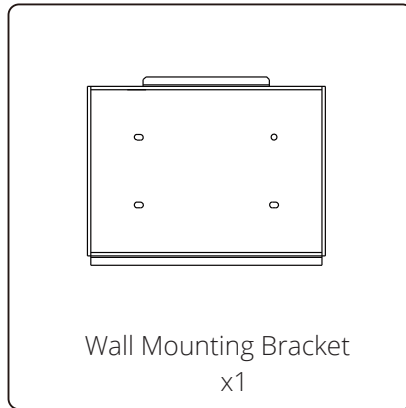
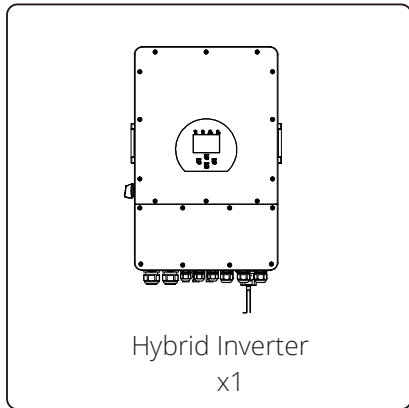

## Selecting the Mounting Area

For proper heat dissipation, allow a clearance of approximately 500mm to the side, 500mm above and below the unit, and 1000mm to the front of the unit.

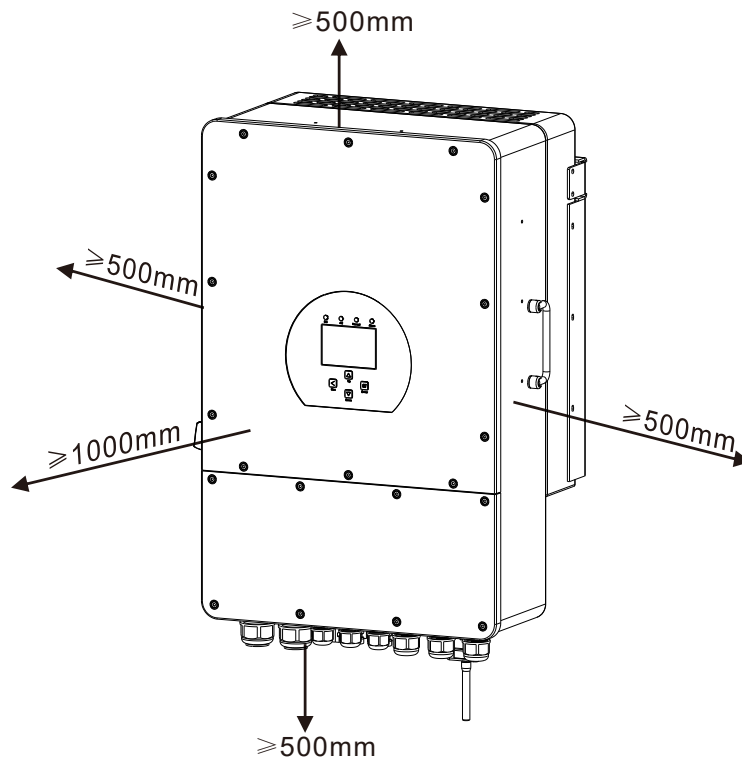

### DO NOT install the inverter in the following areas:

- Areas with high salt content, such as the marine environment. It will deteriorate the metal parts and possibly lead to water/dampness penetrating the unit.
- Areas filled with mineral oil or containing splashed oil or steam, such as those found in kitchens. It will deteriorate plastic parts of the unit, causing those parts to fail or allowing water/damp to penetrate the unit.
- Areas that generate substances that adversely affect the equipment, such as sulphuric gas, chlorine gas, acid, or alkali. These can cause the copper pipes and brazed joints to corrode and fail to conduct electricity reliably.
- Areas that can cause combustible gas to leak, which contains suspended carbon-fibre or flammable dust, or volatile inflammable such as paint thinner or gasoline.
- Areas where there may be gas leaks and where gas may settle around the unit as this is a fire risk.
- Areas where animals may urinate on the unit or ammonia may be generated.
- High altitude areas (over 2000 metres above sea level).
- Environments where precipitation or humidity is above 95%
- Areas where the air circulation is too low.

### ALSO CONSIDER:

- Installing the indoor unit, outdoor unit, power supply cable, transmission cable, and remote control cable at least 1 metre away from any television or radio receiver. This will prevent TV reception interference or radio noise. This will prevent radio signal interference from external units that might interfere with the Wi-Fi or GSM monitoring.

- If children under 10 years old may approach the unit, take preventive measures so they cannot reach and touch the unit.
- Install the indoor unit on the wall where the floor height is higher than 1600mm.

Before connecting all wires, please take the metal cover off, removing the screws as shown below:

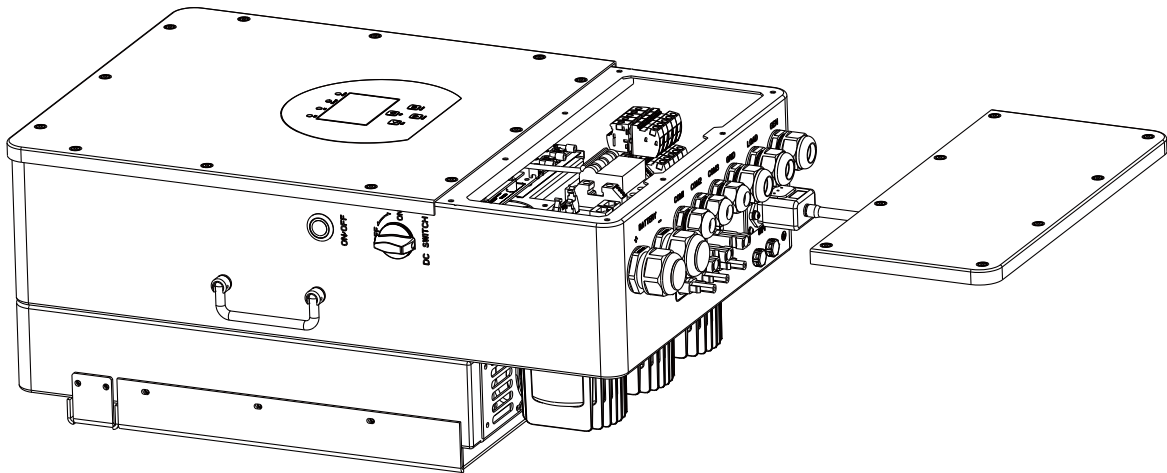

## Mounting the Inverter

- Select installation locations that are adequate to support the weight of the converter.
- Install this inverter at eye level to allow the LCD to be read anytime.
- To ensure optimal operation, an appropriate ambient temperature is between -40 and 60°C.
- Be sure to keep other objects and surfaces, as shown in the figure to guarantee sufficient heat dissipation and have enough space to remove wires.



### WARNING

**Risk of injury (Heavy Object).**

Remember that this inverter is heavy, so users must carefully handle the unit during installation, especially when mounting or removing it from a wall.

Choose the recommended drill head(as shown below) to drill 4 holes on the wall, 82-90mm deep.

1. Use a proper hammer to fit the expansion bolt into the holes.
2. Carry the inverter and hold it, ensure the hanger aims at the expansion bolt, and fix the inverter on the wall.
3. Fasten the screw head of the expansion bolt to finish the mounting.

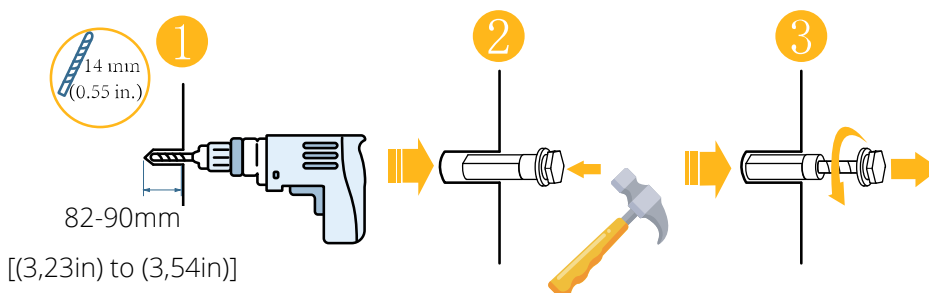

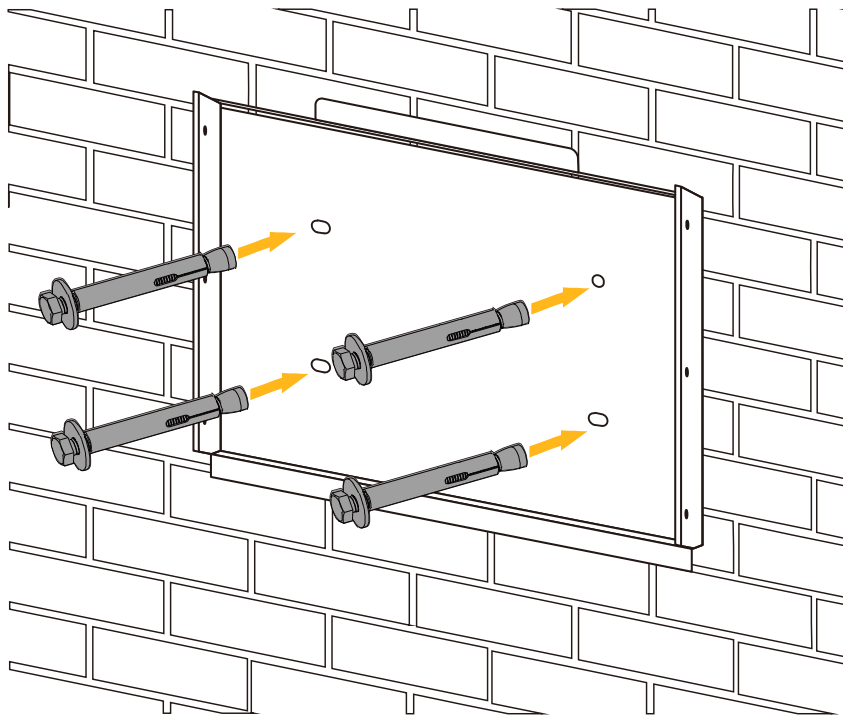

Inverter hanging plate installation

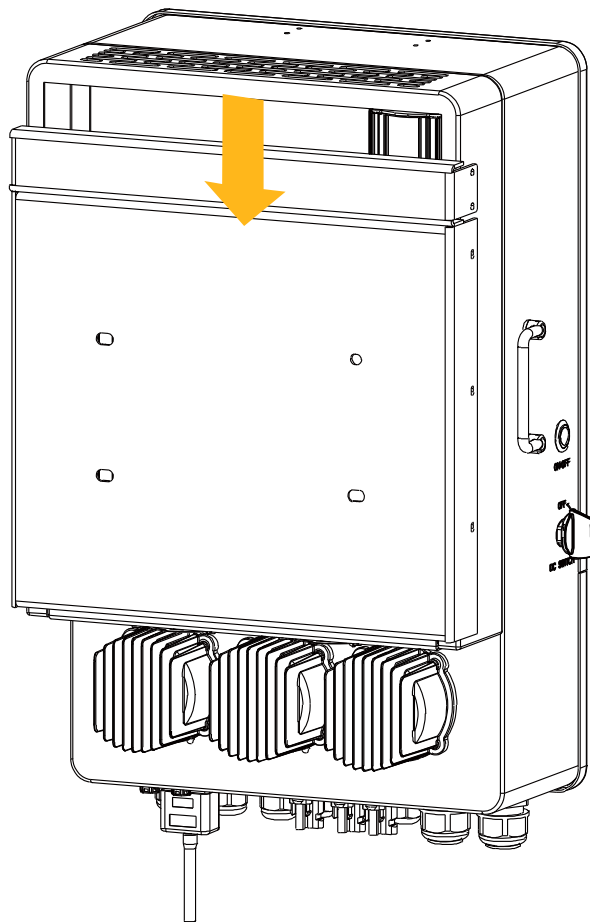



# Battery Connection

For safe operation and compliance, an individual DC overcurrent protector or disconnection device is required to connect the battery and the inverter. Users are recommended to utilise a suitable fuse and DC isolator (see next page). Switching devices may not be required in some applications, but overcurrent protectors must be used. Please refer to the typical amperage in the table below for the required fuse or circuit breaker size.

| Model | Wire Size | Cable (mm <sup>2</sup> ) | Torque Value (max.) |
|-------|-----------|--------------------------|---------------------|
| 8kW   | 3/0AWG    | 70                       | 24.5N.m             |
| 10kW  | 4/0AWG    | 95                       | 24.5N.m             |
| 12kW  | 250kcmil  | 120                      | 24.5N.m             |

Please follow the below steps to implement battery connection:

1. Please choose a suitable battery cable (appropriate rating) with the correct connector to attach to the battery terminals.
2. Use a suitable screwdriver that matches the bolt size to unscrew the bolts to fit the battery connectors. Then tighten the bolts with the connectors in place with a torque of 24.5N.m in a clockwise direction.
3. Make sure the polarity is correct at both the battery and inverter terminals.

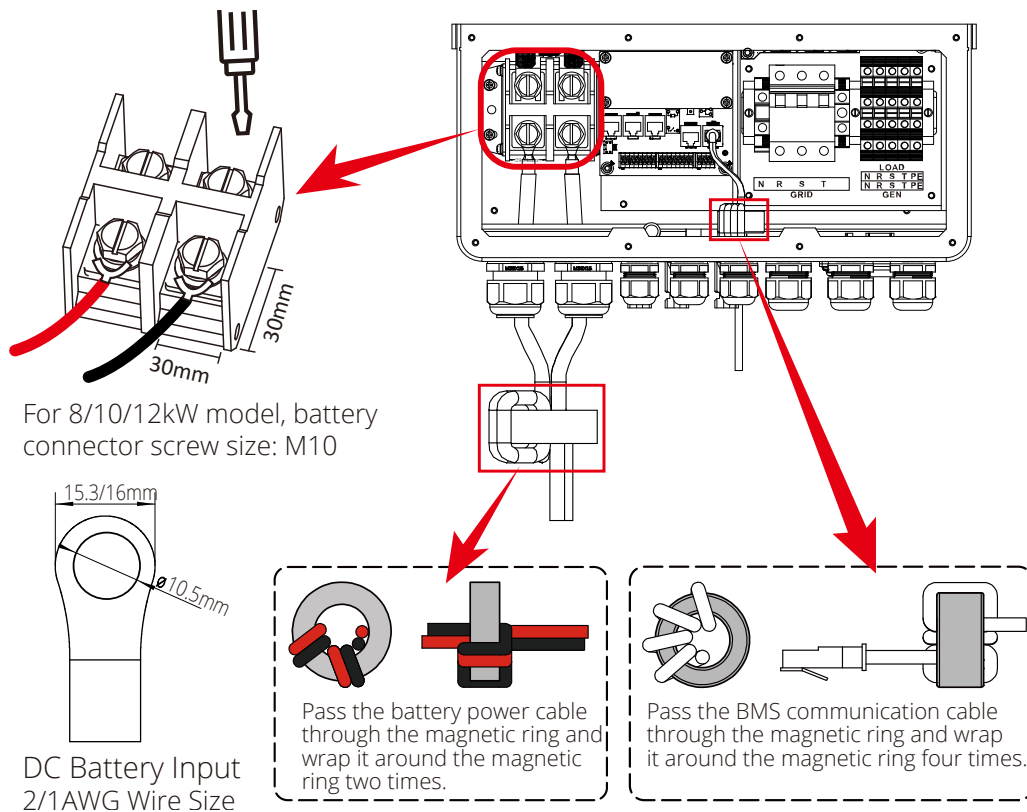

## WARNING

### Reverse Polarity.

Before making the final DC connection or closing DC breaker/disconnect, be sure positive (+) must be connected to the positive (+) and negative (-) must be connected to the negative (-). A reverse polarity connection on the battery will damage the inverter.

All wiring/connecting must be performed by qualified personnel. In addition, connecting the battery with a suitable cable is essential for safe and efficient operation of the system.

# Function Port Definition

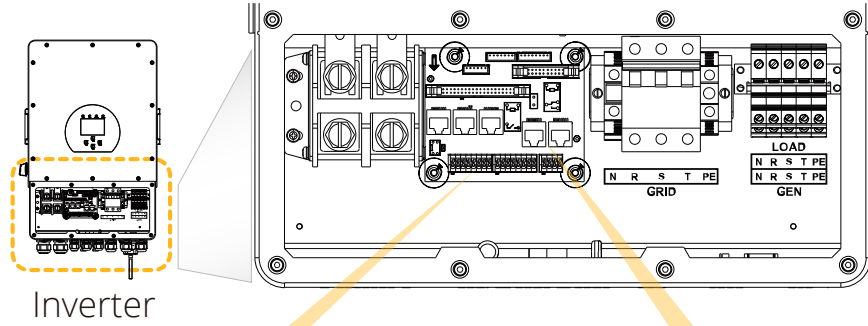

| CN1       |   |   |   | CN2          |   |   |   |
|-----------|---|---|---|--------------|---|---|---|
| TEMP: 1,2 |   |   |   | G_start: 1,2 |   |   |   |
| CT 1: 3,4 |   |   |   | G_valve: 3,4 |   |   |   |
| CT 2: 5,6 |   |   |   | Grid_Ry: 5,6 |   |   |   |
| CT 3: 7,8 |   |   |   | RSD: 7+, 8-  |   |   |   |
| 1         | 2 | 3 | 4 | 1            | 2 | 3 | 4 |
| 5         | 6 | 7 | 8 | 5            | 6 | 7 | 8 |

Batt Temp Sensor

CT -L1

CT -L2

CT -L3

Gen start-up N/O Relay

**CN1:**

**TEMP (1,2):** battery temperature sensor for lead acid battery.

**CT-L1 (3,4):** current transformer (CT1) for "zero export to CT" mode clamps on L1 when in three phase system.

**CT-L2 (5,6):** current transformer (CT2) for "zero export to CT" mode clamps on L2 when in three phase system.

**CT-L3 (7,8):** current transformer (CT3) for "zero export to CT" mode clamps on L3 when in three phase system.

**CN2:**

**G-Start (1,2):** dry contact signal for startup the diesel generator. When the "GEN signal" is active, the open contact (GS) will switch on (no voltage output).

**G-valve (3,4):** Dry contact output. When the inverter is in off-grid mode and the "Signal ISLAND MODE" is checked, the dry contact will switch on.

**Grid\_Ry (5,6):** reserved.

**RSD (7,8):** When the battery is connected and the inverter is in "ON" status, it will provide 12Vdc.

Parallel\_A Parallel\_B Meter-485 Modbus BMS

**Parallel A:** Parallel communication port 1 (CAN interface).

**Parallel B:** Parallel communication port 2 (CAN interface).

**Meter\_485:** for energy meter communication

**Modbus:** Reserved.

**BMS:** BMS port for battery communication (CAN/RS485).

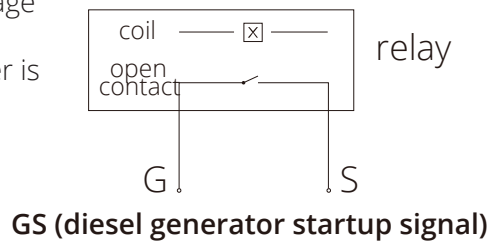

# Lead-Acid Battery Temperature Sensor

Without a remote temperature sensor, lead-acid batteries may undercharge or overcharge depending on the ambient temperature of the installation environment. This may result in a fire hazard.

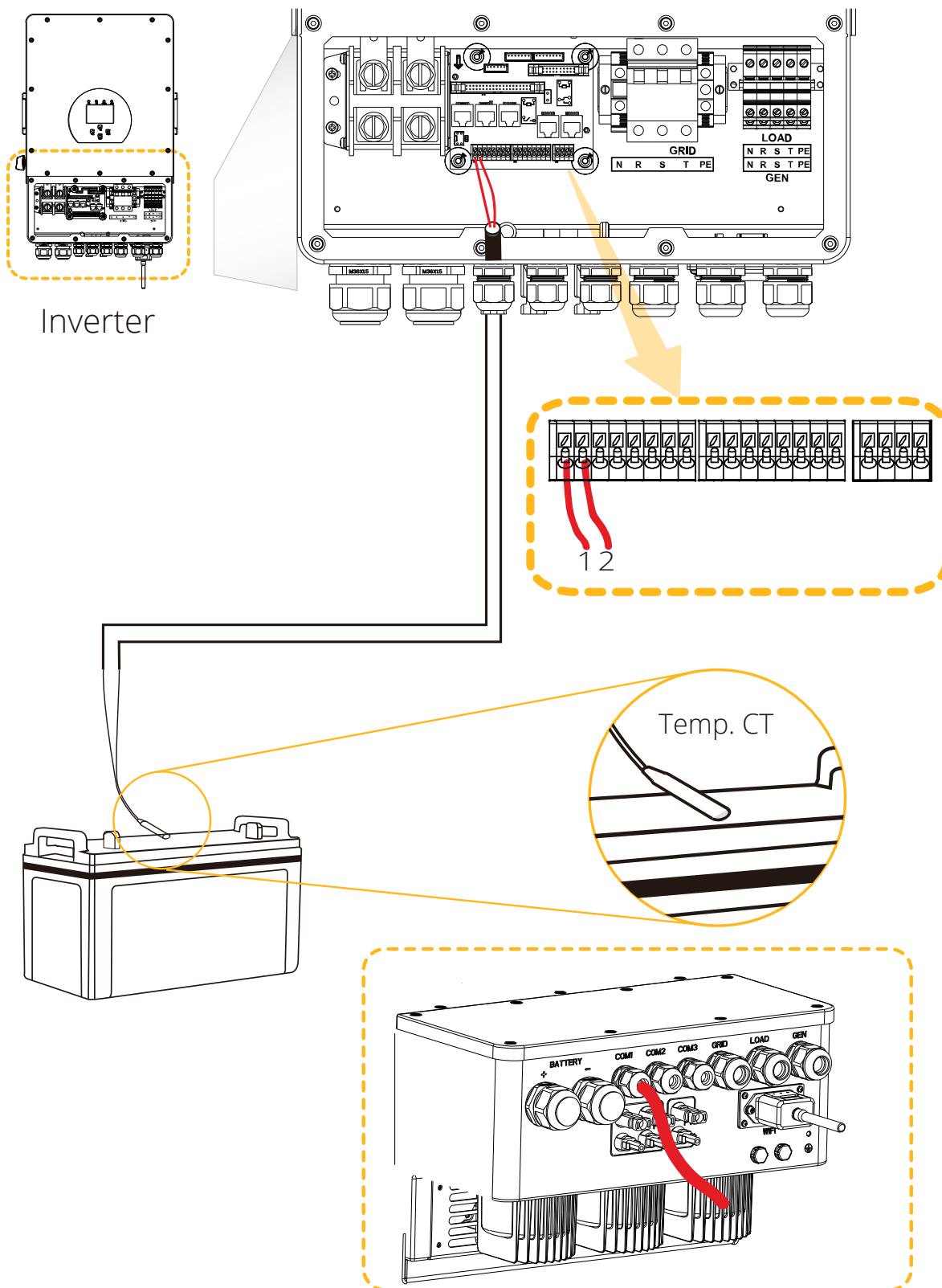

## AC and Backup Load Connection

Before connecting to the main grid, please install a separate AC Breaker (MCB) between the inverter and the grid. In addition, it is recommended the installation of an AC Breaker between the backup load and inverter. This will ensure the inverter can be disconnected safely during maintenance and fully protect the system from over-current. The recommended of AC breaker for the load port is 63A for 8kW, 63A for 10kW and 63A for 12kW. The recommended of AC breaker for the grid port is 63A for 8kW, 63A for 10kW and 63A for 12kW. There are three terminal blocks marked as GRID, LOAD, and GEN. Please do not confuse input and output connections.

|                |   |
|----------------|---|
| <b>GEN/AUX</b> | Generator connection.   |
| <b>GRID</b>    | This works like a conventional grid-tied inverter. It is both an input and output connection for non-essential load and supply. |
| <b>LOAD</b>    | Connection of essential loads such as lighting, security systems, and internet.   |



### WARNING

All wiring must be performed by qualified personnel. System safety and efficient operation need to use appropriate cable for AC input connection. To reduce the risk of injury, please use the recommended cable below.

#### Grid connection and backup load connection (Copper Wires)

| Model  | Wire Size | Cable (mm <sup>2</sup> ) | Torque Value (max.) |
|--------|-----------|--------------------------|---------------------|
| 8/10kW | 12AWG     | 2.5                      | 1.2N.m              |
| 12kW   | 10AWG     | 4                        | 1.2N.m              |

#### Grid connection and backup load connection (Copper Wires) (bypass)

| Model     | Wire Size | Cable (mm <sup>2</sup> ) | Torque Value (max.) |
|-----------|-----------|--------------------------|---------------------|
| 8/10/12kW | 6AWG      | 10                       | 1.2N.m              |

Please follow the steps below to implement GRID, LOAD, and GEN port connections:

1. Before making GRID, LOAD, and GEN port connections, make sure to turn off the AC breaker or disconnector first.
2. Remove a 10mm sleeve from each wire, unscrew the bolts, insert the cables according to the polarities indicated on the terminal block and tighten the terminal screws. Ensure the connection is complete.
3. Then, insert AC output wires according to the polarities indicated on the terminal block and tighten the terminal. Make sure to connect corresponding N wires and PE wires to related terminals as well.
4. Ensure the wires are securely connected.
5. Check that the AC power source is isolated before attempting to connect it to the inverter. Insert AC output wires according to the polarities indicated on the terminal block and tighten the terminal screws. Be sure to connect the corresponding N wires and PE wires to the correct terminals and ensure the wires are securely connected.

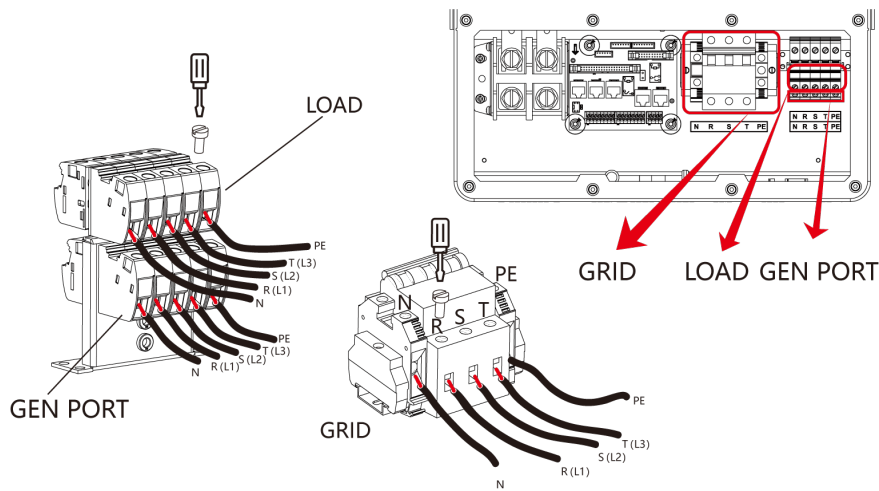

## PV Connection

Before connecting to PV modules, please install a separate DC circuit breaker between the inverter and PV modules. It is very important for system safety and efficient operation to use appropriate cable for PV module connection. To reduce the risk of injury, please use the recommended cable size below.

| Model     | Wire Size | Cable (mm <sup>2</sup> ) |
|-----------|-----------|--------------------------|
| 8/10/12kW | 12AWG     | 2.5                      |



### WARNING

To avoid malfunction, do not connect any PV modules with possible leakage current to the inverter. For example, grounded PV modules will cause leakage current to the inverter. When using PV modules, please ensure the PV+ & PV- of the solar panel are not connected to the system ground bar.

It is requested to use a PV junction box with surge protection. Otherwise, it will cause damage to the inverter when lightning occurs on PV modules.

## PV Module Selection

When selecting the PV modules, you should consider the following parameters:

1. Open-circuit voltage (Voc) of PV modules does not exceed the maximum PV array Voc.
2. Open-circuit voltage (Voc) of PV modules should be higher than the minimum start voltage of the inverter.

| Inverter Model                 | 8kW              | 10kW | 12kW |
|--------------------------------|------------------|------|------|
| PV Input Voltage               | 550V (160V~800V) |      |      |
| PV Array MPPT Voltage Range    | 200V~650V        |      |      |
| No. of MPP Trackers            | 2                |      |      |
| No. of Strings per MPP Tracker | 1+1              | 2+1  |      |

## PV Module Wiring

1. Switch the Grid Supply Main Switch (AC) OFF.
2. Switch the DC isolator OFF.
3. Assemble PV input connector to the inverter.
4. Use the MC4 connectors supplied by Sunsynk with the inverter.



DC+ male connector (MC4)

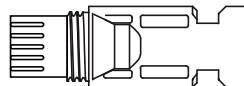

DC+ female connector (MC4)



## WARNING

Before connection, please ensure the polarity of the output voltage of the PV array matches the DC+ and DC- symbols.

Please do not connect the PV array's positive and negative poles to the ground. This can seriously damage the inverter.

Before connecting the inverter, please make sure the PV array open-circuit voltage is within the maximum limit of the inverter.

Please utilise an approved DC cable for the PV system.

| Cable type                                  | Cross section (mm <sup>2</sup> ) |                   |
|---|----------------------------------|-------------------|
|   | Range                            | Recommended value |
| Industry generic PV cable<br>(model: PV1-F) | 2.5~4.0 (12~10 AWG)              | 2.5 (12 AWG)      |

The correct steps in assembling the DC connector are explained below:

- Strip 7mm of the plastic coating off the DC wire and disassemble the connector cap nut.

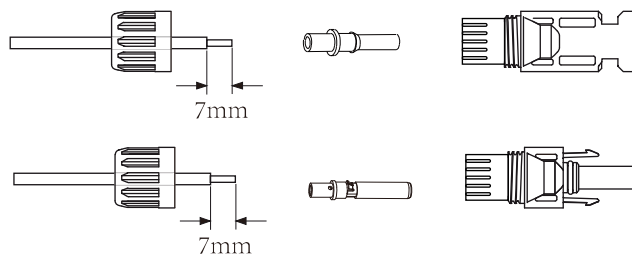

- Crimp metal terminals with crimping pliers.

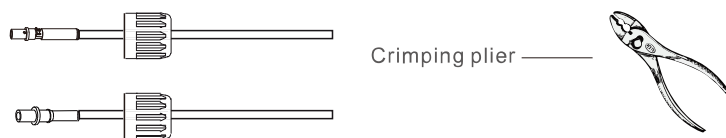

- Insert the contact pin into the connector housing until it locks into place. Then screw the cap nut onto the connector housing. Torque to 2.5-3 N.m.

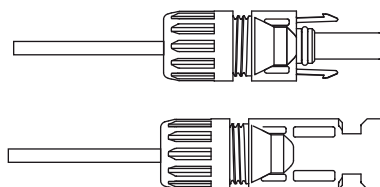

- Finally, insert the DC connector into the positive and negative input of the inverter.

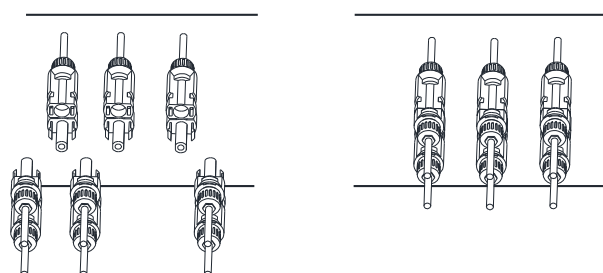



## NOTE:

When sunlight falls on the solar panel, it will generate a voltage. A high voltage generated by panels in a series configuration may cause danger to life. Therefore, before connecting the DC-Input line, the solar panel's surface should be shielded from the sun's rays by some opaque material, and the DC switch should be off. This will prevent a high voltage from flowing to the inverter, thereby causing risk to persons conducting installation or maintenance.

## Connecting the CT Coil

The CT coil is one of the most important parts of the Sunsynk inverter. This device reduces the power of the inverter to prevent feeding power to the grid. This feature is also known as "Zero Export".

1. Fit the coil (sensor) around the live cable on the main fuse feeding the building and run the cable back to the inverter. If using an external meter, you can extend the cable for more than 10 metres. Please consult the meter manual on distance.
2. Connect the other end of the CT coil to the inverter terminals.

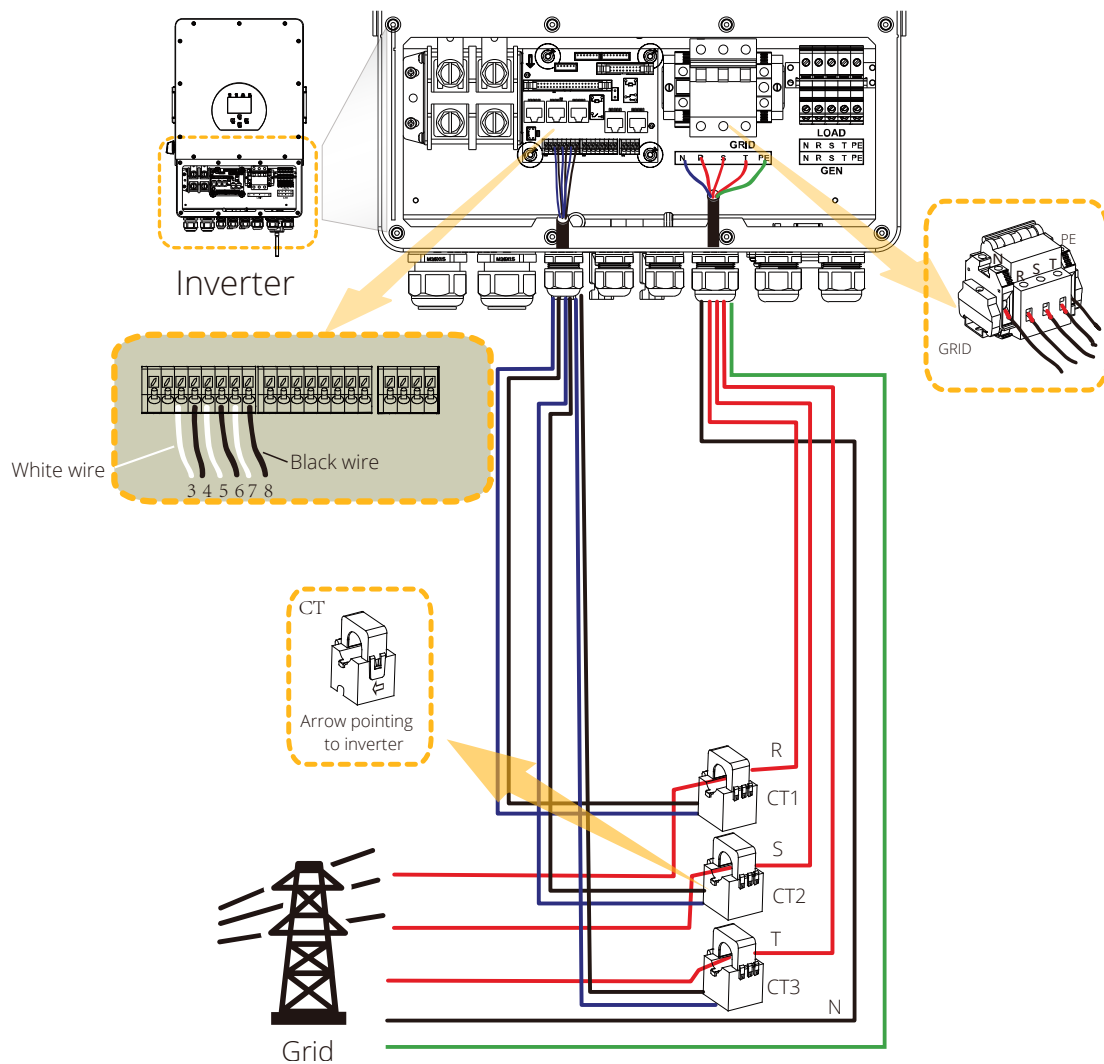

## NOTE:

When the inverter is in the off-grid state, the N line needs to be connected to the earth.



# Meter Connection

## CHiNT Meter

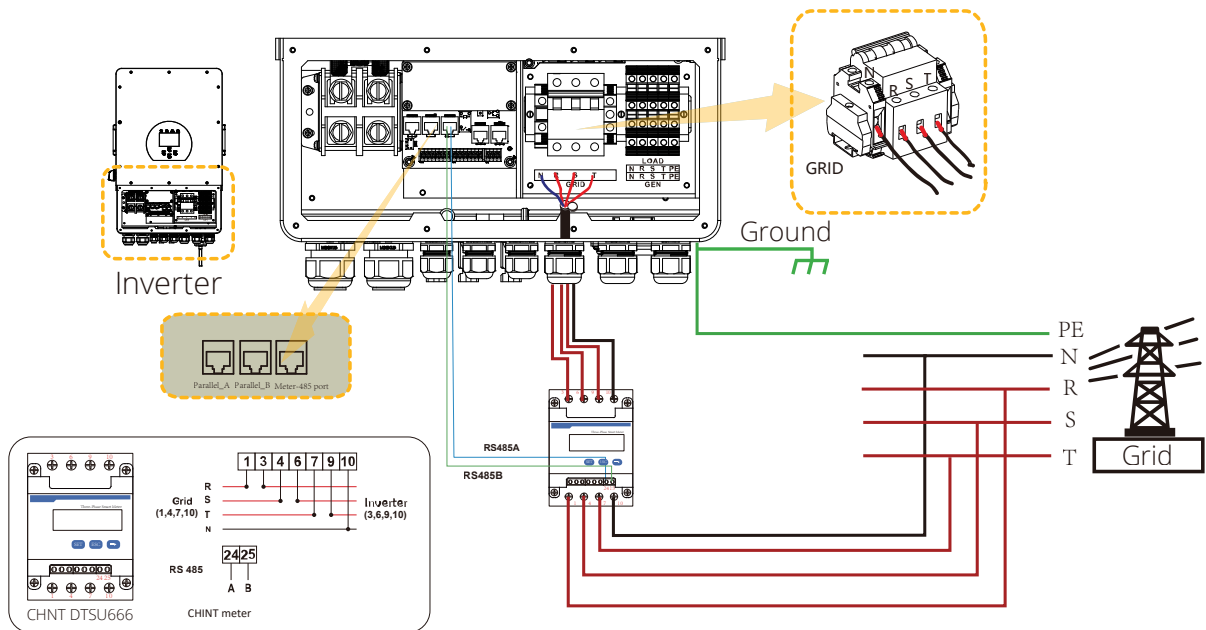

## Eastron Meter

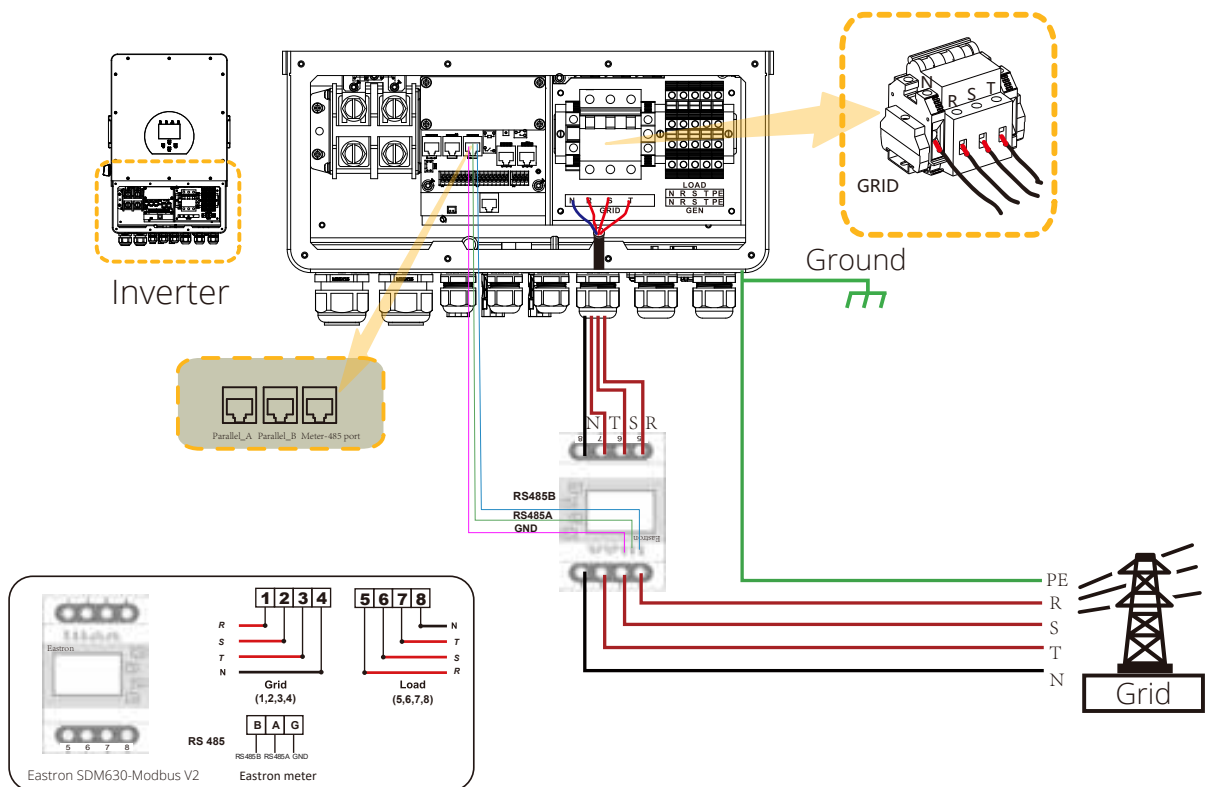

# Earth Connection (MANDATORY)

An Earth Cable shall be connected to the earth plate on the grid size in order to prevent electric shock if the original protective conductor fails.

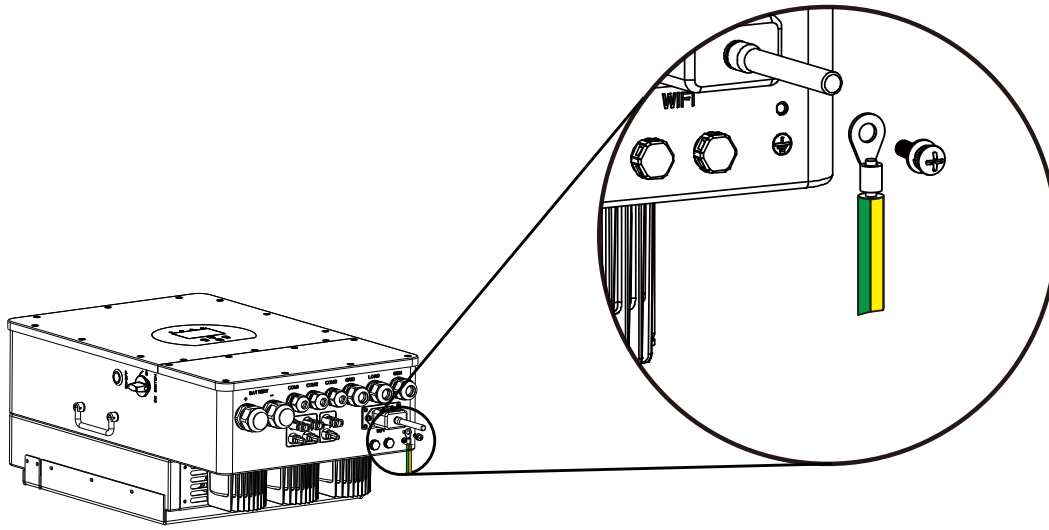

All neutrals can be linked together to maintain the neutral bond. When a Neutral Earth bond is required for an 'Off-grid' operation, then it has to be removed on 'Grid-Tied' operation.

If an Earth Bond is required between neutral and earth and your system is a hybrid system, then you can have a permanent earth wire since this can cause faults with an RCD before the inverter.

Since the inverter is a true hybrid, then the bond must only be made when the inverter is operating in Islanding Mode. To accommodate this, Sunsynk provides an AC output, which is connected to the A/T/S connections whenever the inverter is running on Island Mode. Therefore, you can simply connect the coil of an AC relay to the ATS 240 connections. Next, you need to select Signal Island Mode on the battery charge menu (click on the gear icon -> battery icon), as shown in the figure below.

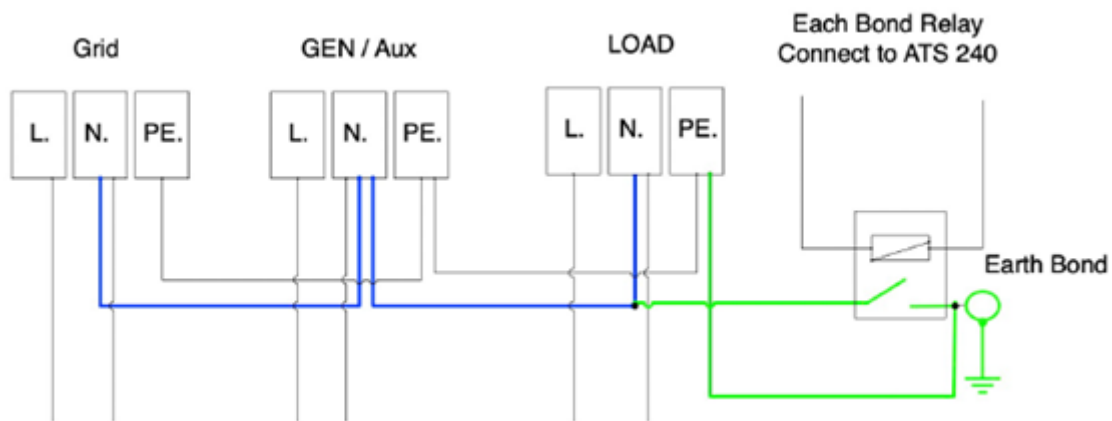

Earth connection (Copper Wires)

| Model  | Wire Size | Cable (mm <sup>2</sup> ) | Torque Value (max.) |
|--------|-----------|--------------------------|---------------------|
| 8/10kW | 12AWG     | 2.5                      | 1.2N.m              |
| 12kW   | 10AWG     | 4                        | 1.2N.m              |

Earth (Copper Wires) (bypass)

| Model     | Wire Size | Cable (mm <sup>2</sup> ) | Torque Value (max.) |
|-----------|-----------|--------------------------|---------------------|
| 8/10/12kW | 6AWG      | 10                       | 1.2N.m              |



**NOTE:**

The grid power may still be present, but the inverter is not draining power from it since the unit is working in 'Island Mode'.

### Battery Setup

**Batt type** | **Batt charge** | **Shut Down**

|  |   |                                      |  |                                    |
|--|---|--------------------------------------|--|------------------------------------|
| Amps   | <input type="text" value="40A"/>                | <input type="text" value="5A"/>      | Float V                                | <input type="text" value="55.2V"/> |
| <input type="checkbox"/> Gen Charge                    | <input checked="" type="checkbox"/> Grid Charge | Absorption V                         | <input type="text" value="57.6"/>      |                                    |
| <input type="checkbox"/> Gen Signal                    | <input checked="" type="checkbox"/> Grid Signal | Equalization V                       | <input type="text" value="58.8V"/>     |                                    |
| <input checked="" type="checkbox"/> Signal ISLAND MODE | <input type="text" value="Force OFF"/>          | <input type="text" value="90 days"/> | <input type="text" value="2.0 hours"/> |                                    |
| <input type="checkbox"/> Gen Force                     | <input type="text" value="Cancel"/>             | <input type="text" value="OK"/>      |  |                                    |

You can verify if there is a voltage when the inverter is disconnected from the grid by using a simple multimeter.



**NOTE:**

Only for South Africa – Using a permanent PE/N bond on LOAD OUTPUT is recommended, and the supply power to the grid port needs to be taken from the mains before the main RCD to prevent RCD from tripping.

The bond we recommend being done in the external box clearly marked “permanent PE/N bond”, and this has been advised by local authorities.

# Wiring System for Inverter

The following diagram is an example of an application where the neutral connects with the PV in a distribution box.

For countries such as Australia, New Zealand, South Africa, etc., please follow local wiring regulations!

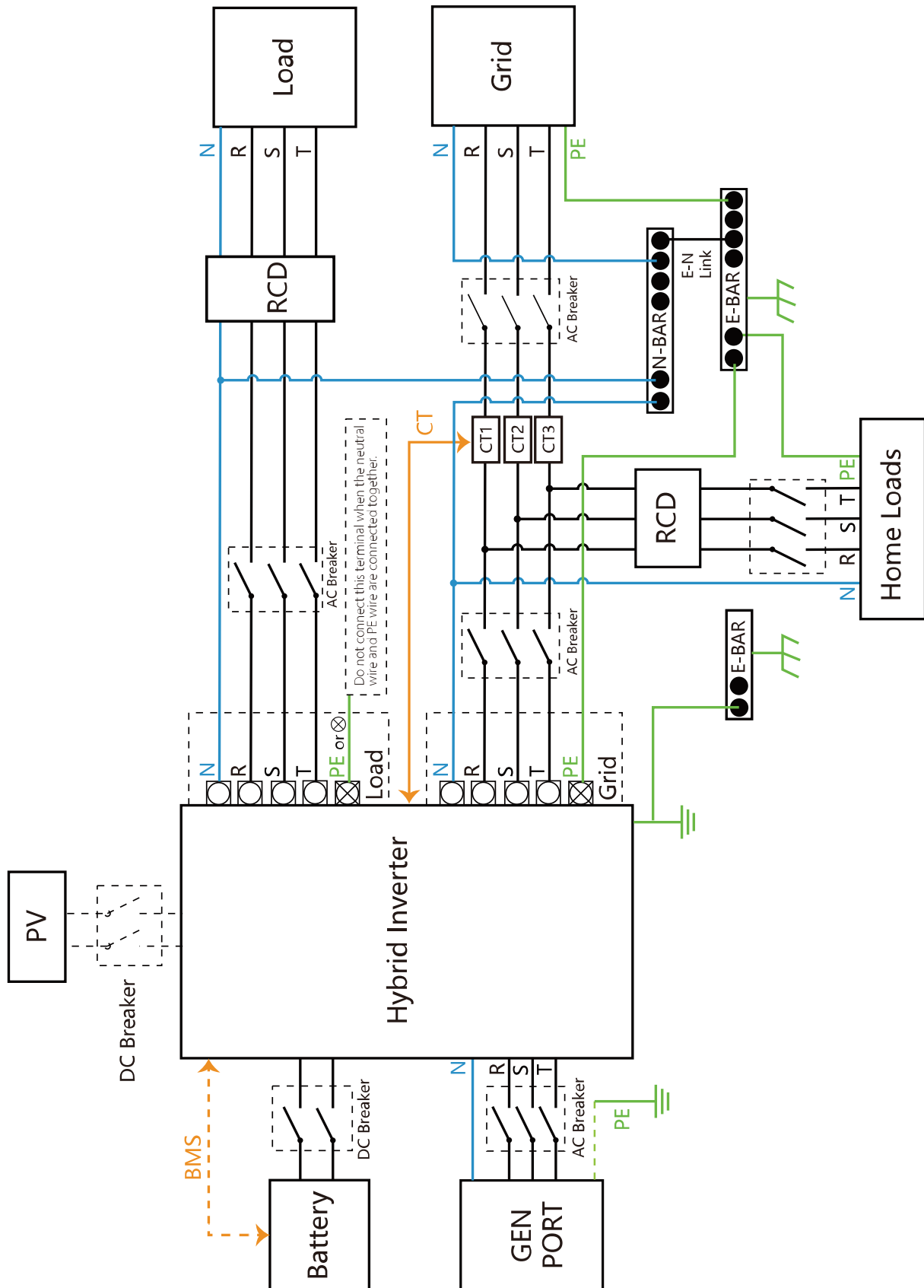

# Wiring Diagram

This diagram is an example for an application in which neutral is separated from the PE in the distribution box. For countries such as China, Germany, the Czech Republic, Italy, etc., please follow local wiring regulations!

Note: Backup function is optional in German market, please leave backup side empty if backup function is not available in the inverter.

When the inverter is working in backup mode, neutral and PE on the backup side are connected via the internal relay. Also, this internal relay will be open when the inverter is working in grid tied mode.

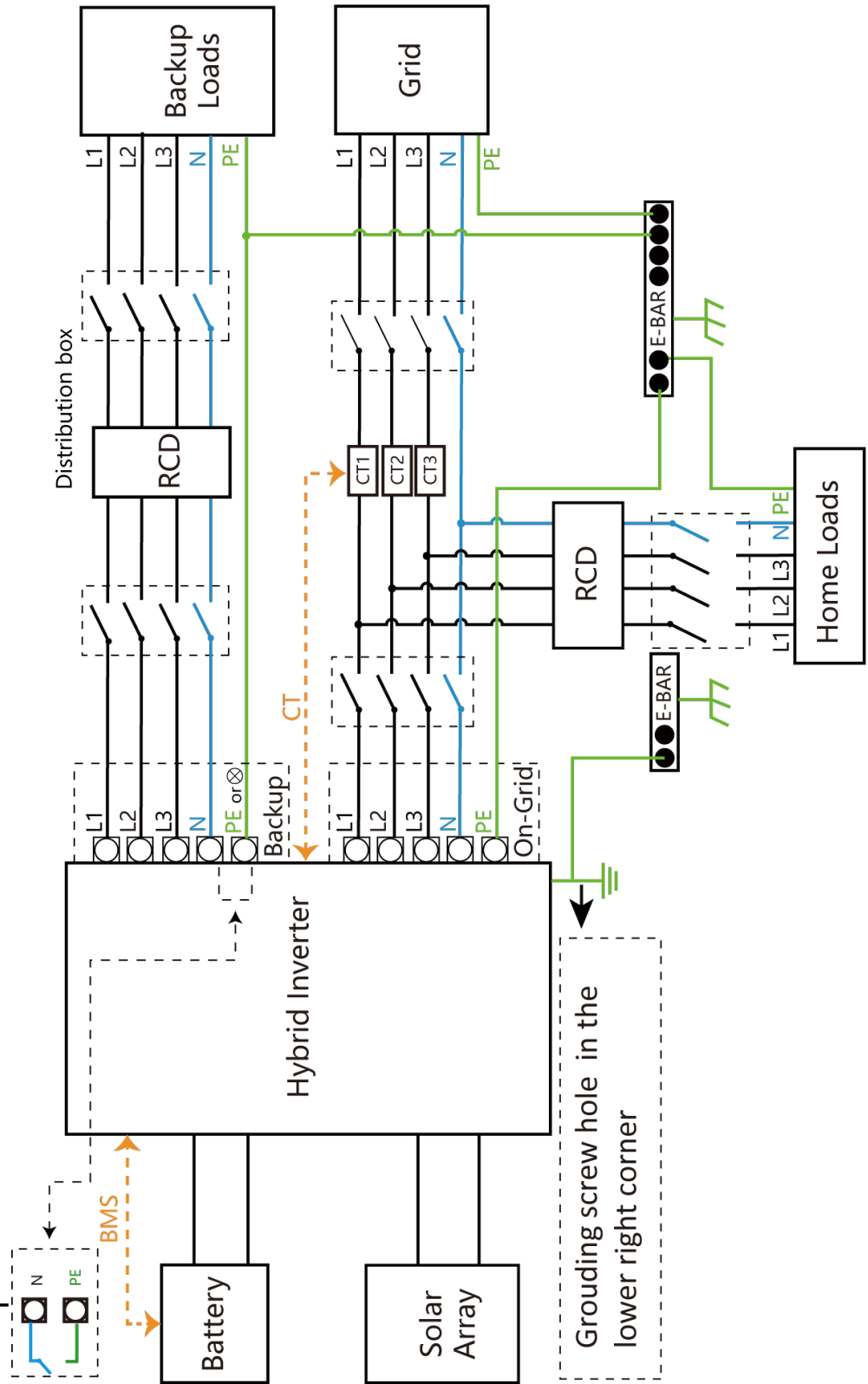

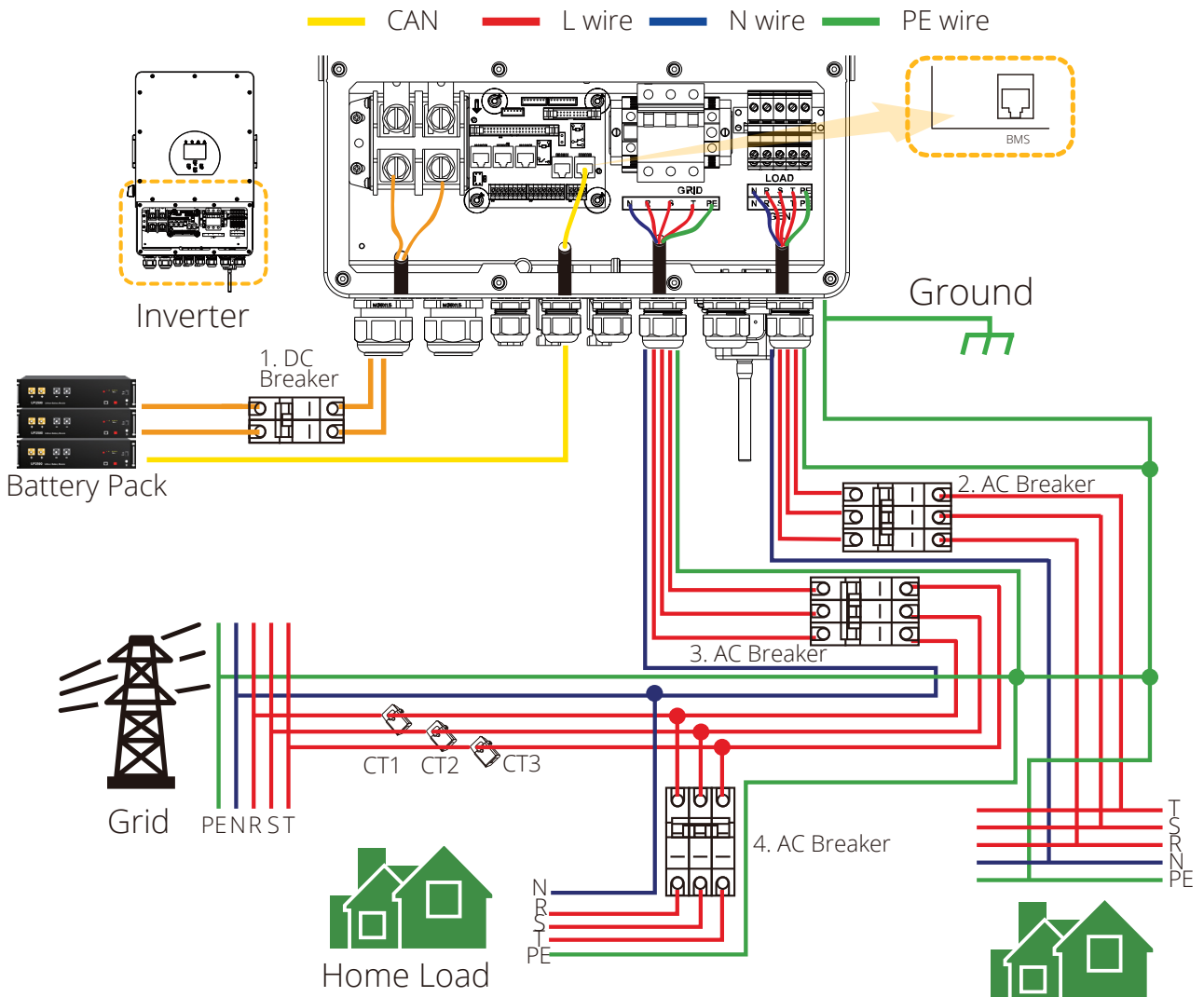

1. DC Breaker for battery  
 SYNK-8K-SG04LP3: 250A DC breaker  
 SYNK-10K-SG04LP3: 300A DC breaker  
 SYNK-12K-SG04LP3: 300A DC breaker

2. AC Breaker for backup load  
 SYNK-8K-SG04LP3: 63A AC breaker  
 SYNK-10K-SG04LP3: 63A AC breaker  
 SYNK-12K-SG04LP3: 63A AC breaker

3. AC Breaker for grid  
 SYNK-8K-SG04LP3: 63A AC breaker  
 SYNK-10K-SG04LP3: 63A AC breaker  
 SYNK-12K-SG04LP3: 63A AC breaker

4. AC Breaker for home load  
 Depends on household loads

# Typical Application of Diesel Generator

— CAN   
 — L wire   
 — N wire   
 — PE wire

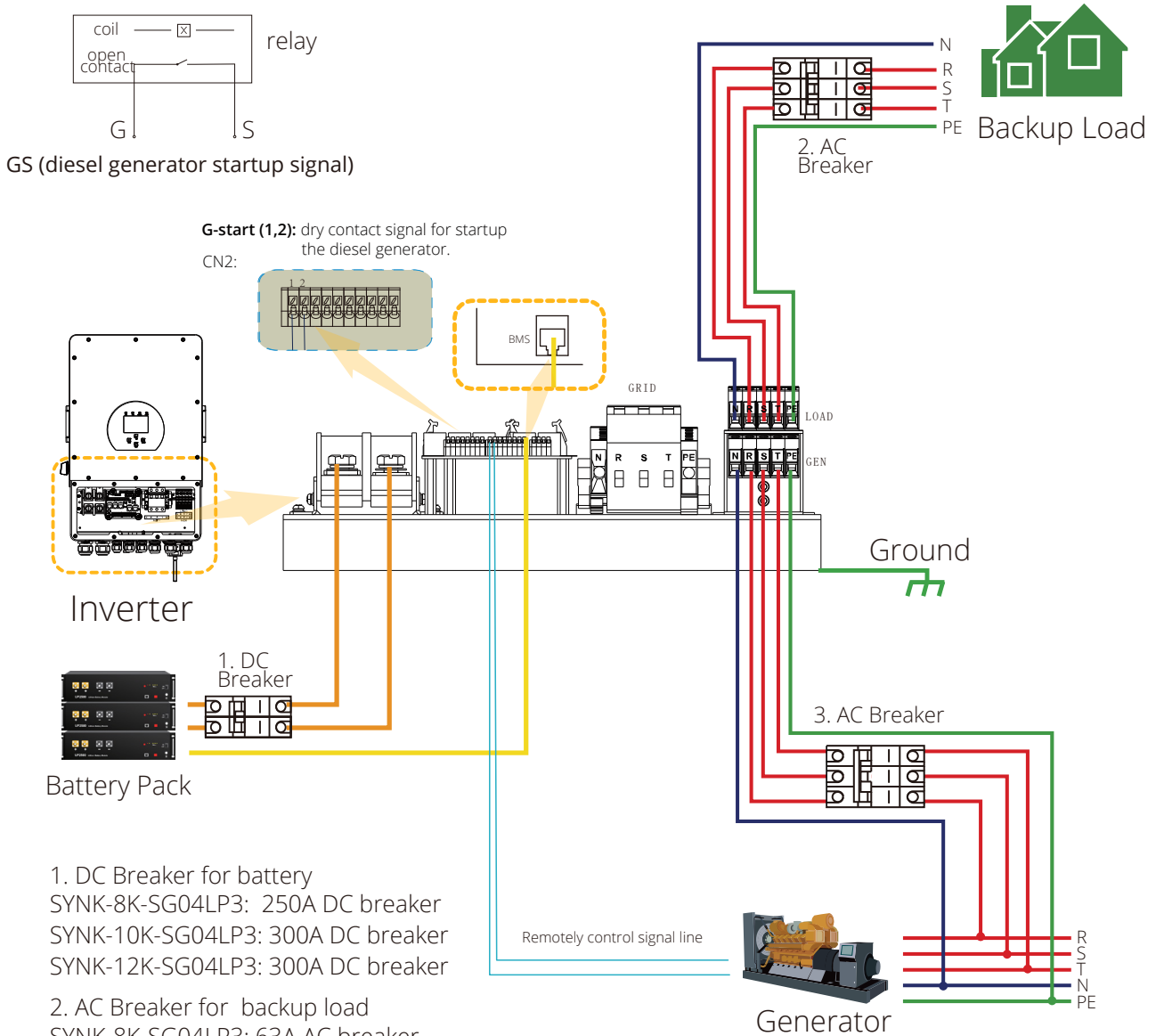

1. DC Breaker for battery  
 SYNK-8K-SG04LP3: 250A DC breaker  
 SYNK-10K-SG04LP3: 300A DC breaker  
 SYNK-12K-SG04LP3: 300A DC breaker
2. AC Breaker for backup load  
 SYNK-8K-SG04LP3: 63A AC breaker  
 SYNK-10K-SG04LP3: 63A AC breaker  
 SYNK-12K-SG04LP3: 63A AC breaker
3. AC Breaker for Generator port  
 SYNK-8K-SG04LP3: 63A AC breaker  
 SYNK-10K-SG04LP3: 63A AC breaker  
 SYNK-12K-SG04LP3: 63A AC breaker

# Three Phase Parallel Connection

Max. 10pcs parallel for on-grid and off-grid operation.

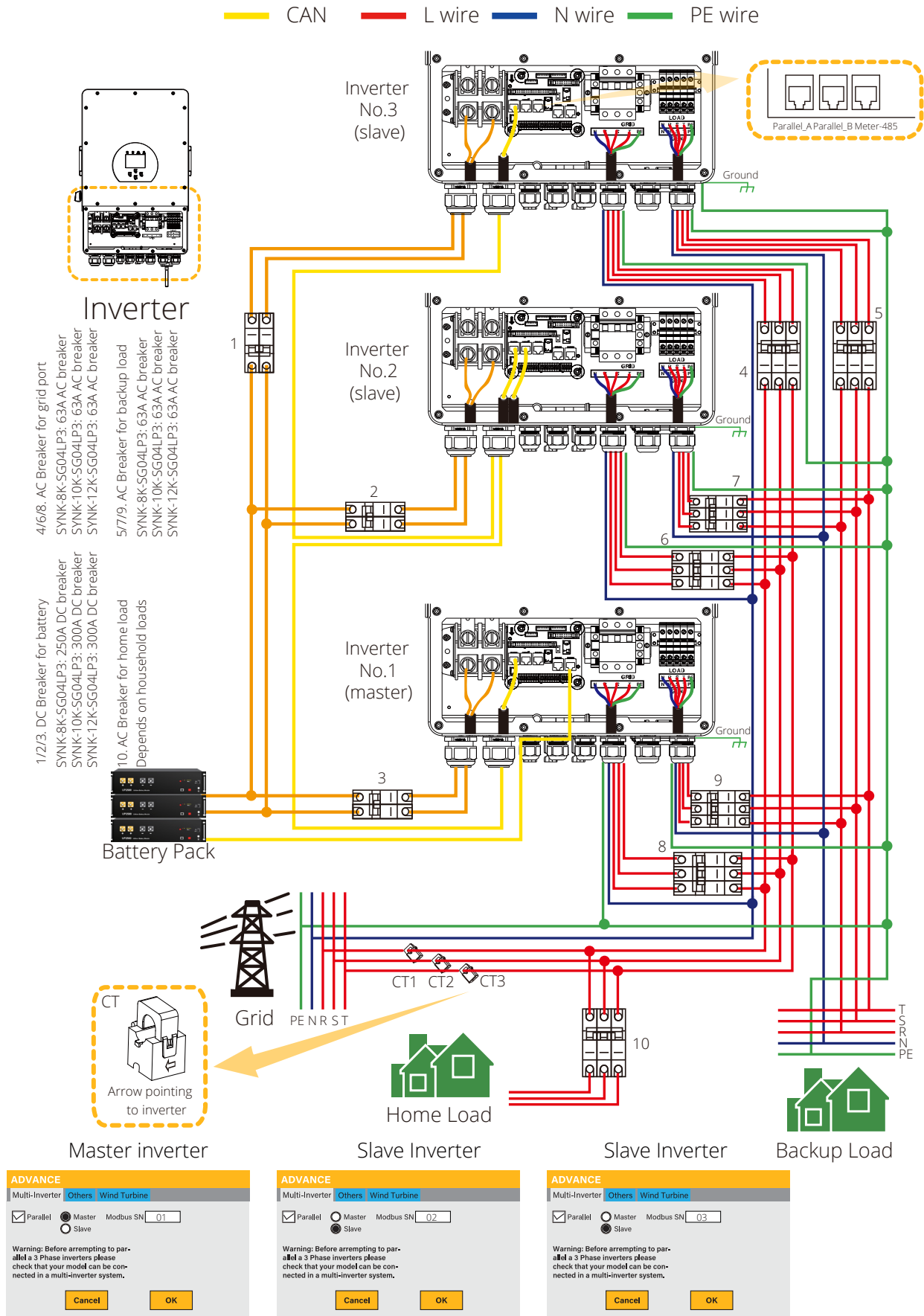



## OPERATION

### Switching ON/OFF

Once the inverter has been correctly installed and the batteries have been connected, press the ON/OFF button (located on the left side of the case) to activate the system. When the system is connected without a battery but connected with either PV or grid and the ON/OFF button is switched off, the LCD will still illuminate (display will show off). In this condition, when switching on the ON/OFF button and selecting 'No Battery', the system can still work.

### Display

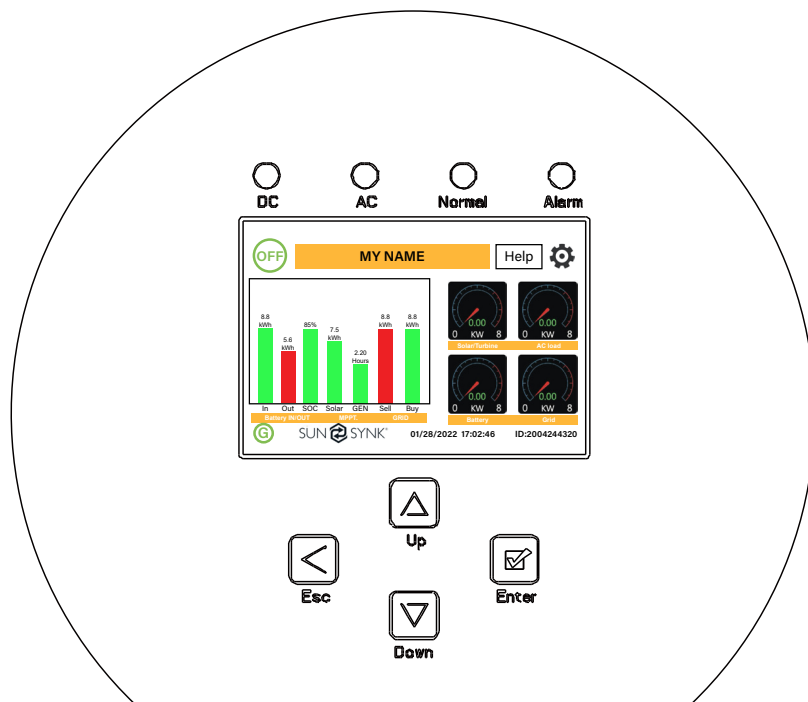

### LED Indicators

| LED indicator | Meaning  |
|---------------|--|
| DC            | Green LED solid light<br>PV connection normal          |
| AC            | Green LED solid light<br>Grid connection normal        |
| Normal        | Green LED solid light<br>Inverter functioning normally |
| Alarm         | Red LED solid light<br>Fault                           |

### Function Buttons

| Function Key | Description   |
|--------------|---|
| Esc          | To exit the previous mode   |
| Up           | Increase the value of a setting   |
| Down         | Decrease the value of a setting   |
| Enter        | Confirm setting change (If not pressed each time the setting will not be saved) |

# LCD Operation Flow Chart

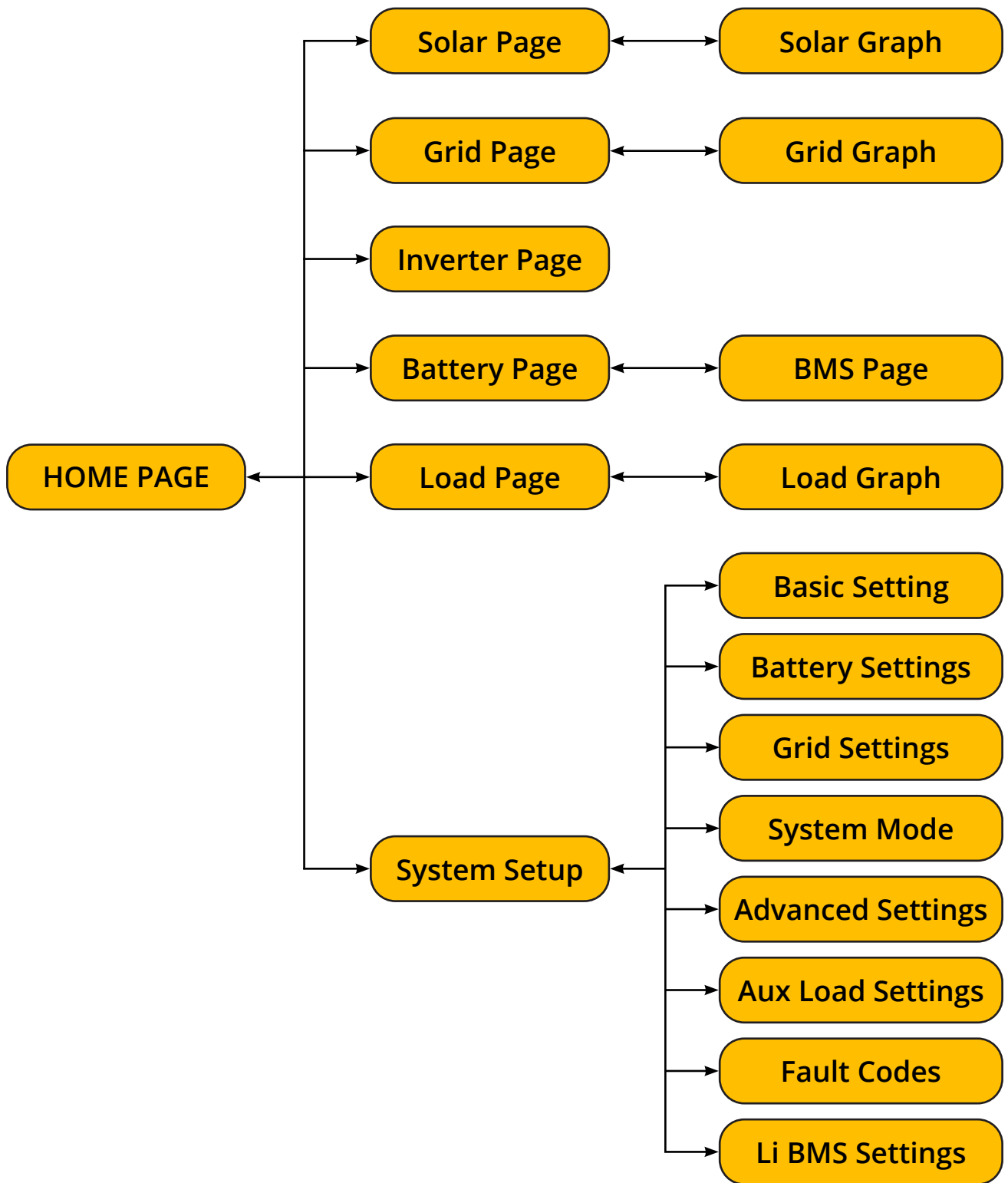

# Home Page

Press the Esc button any page to access the home page:

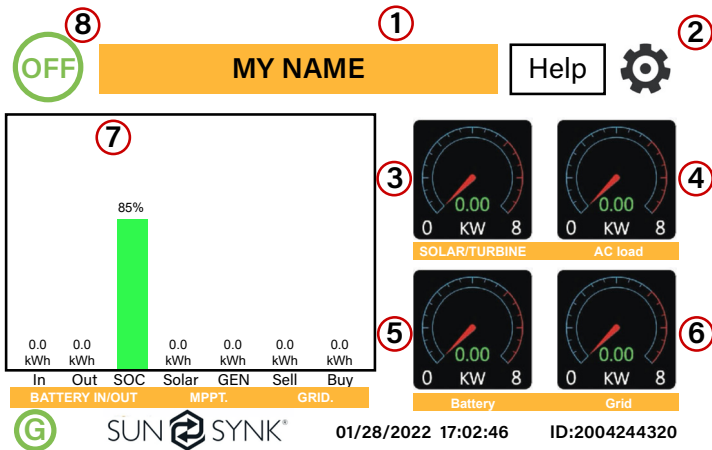

1. Customer name
2. Access the settings menu page
3. Access solar page
4. Access load page
5. Access battery page
6. Access grid page
7. Access system flow page
8. Access fault code displays.

The icon (8) indicates that the system is in Normal operation. If it turns into "comm./F01~F64", the inverter has communication errors or other errors, and the error message will display under this icon (F01-F64 errors, detail error info can be viewed in the System Alarms menu).

## What this page displays:

- Total daily power into the battery (kWh).
- Total daily power out of the battery (kWh).
- SOC (State of charge of the battery) (%).
- Total daily solar power produced in (kWh).
- Total hourly usage of the generator (Time).
- Total daily power sold to the grid (kWh).
- Total daily power bought from the grid (kWh).
- Real-time solar power in (kW).
- Real-time load power in (kW).
- Real-time battery charge power in (kW).
- Real-time grid power in (kW).
- Serial number.
- Time date.
- Access the status page.
- Access the fault code displays.

## Status Page

This page shows the status of Load Power, Grid Power, Inverter Power, Battery, Solar Power 1 and Solar Power 2. To access the Status page, click on the BATTERY or AC LOAD dial on the Home page.

|  |   |   |
|--|---|---|
| 0 W  | 0 W<br>0.0 Hz   | 0 W<br>50.0 Hz  |
| 0V 0W<br>0V 0W<br>0V 0W  | 0V 0.0A<br>0V 0.0A<br>0V 0.0A<br>HM: LD:<br>0W 0W<br>0W 0W<br>0W 0W | 0V -0.1A<br>0V -0.1A<br>0V -0.1A<br>INV_P:<br>0W<br>0W AC_T:<br>0W 24.9 C |
| <b>Load Power</b>  | <b>Grid Power</b>   | <b>Inverter Power</b>   |
| SOC: 100%<br>51W<br>BAT_V: 53.21V<br>BAT_I: 0.97A<br>BAT_T: 100.0C | DC_P1: 0W<br>DC_V1: 0V<br>DC_I1: 0.0A                               | DC_P2: 0W<br>DC_V2: 0V<br>DC_I2: 0.0A                                     |
| <b>Battery</b>   | <b>Solar Power 1</b>  | <b>Solar Power 2</b>  |

## What this page displays:

- Total solar power produced.
- MPPT 1 power/voltage/current.
- MPPT 2 power/voltage/current.
- Grid power.
- Grid frequency.
- Grid voltage.
- Grid current.
- Inverter power.
- Inverter frequency.
- Inverter voltage.
- Inverter current.
- Load power.
- Load voltage.
- Battery power charge/discharge.
- Battery SOC.
- Battery voltage.
- Battery current.
- Battery temperature.

**Solar Column:** Shows total PV (Solar) power, voltage and current for each of the two MPPT.

**Grid Column:** Shows grid total power, frequency, voltage, and current. When selling power to the grid, the power is negative. When consuming from the grid, the power is positive. If the sign of the grid and HM (home) powers are not the same when the PV is disconnected and the inverter is only taking energy from the grid and using the CT connected to Limit-2, then please reverse the polarity of the CT coil. Important: See Section 'Connecting the CT coil'.

**Inverter Column:** Showing inverter total power, frequency, L1, L2, voltage, current, and power.

**Load Column:** Showing total load power, load voltage, and power on L1 and L2.

**Battery Column:** Shows total power from the battery, battery SOC, battery voltage, battery current (negative means charge, positive means discharge) battery temperature (shows zero if the battery temperature sensor is not connected). DC transformer temperature and AC heatsink temperature (When the temperature reaches 90°C, it will display in red, and the performance of the inverter will start deteriorating when it reaches 110°C. Subsequently, the inverter will shut down to allow it to cool and reduce its temperature.

## System Flow Page

Access by clicking on the bar chart on the Home Page.

To better understand the functioning of your system, take a look at the figure at right:

1. The PV modules charge the batteries.
2. When the batteries reach a specific level (programmable), the battery power is fed into the inverter.
3. The inverter can then supply power to the grid (export or no export), load, and auxiliary or smart load.
4. CT coil controls the export power.

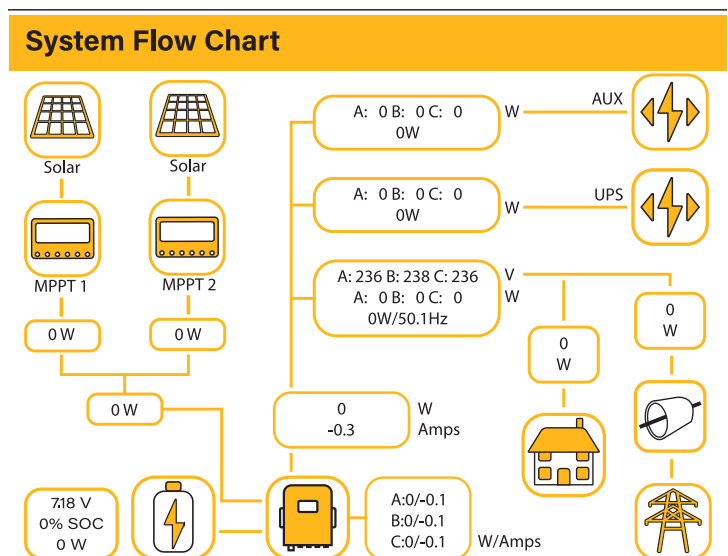

**What this page displays:**

- The system flow.
- MPPTs power.
- Battery status.
- Power distribution to load or grid.

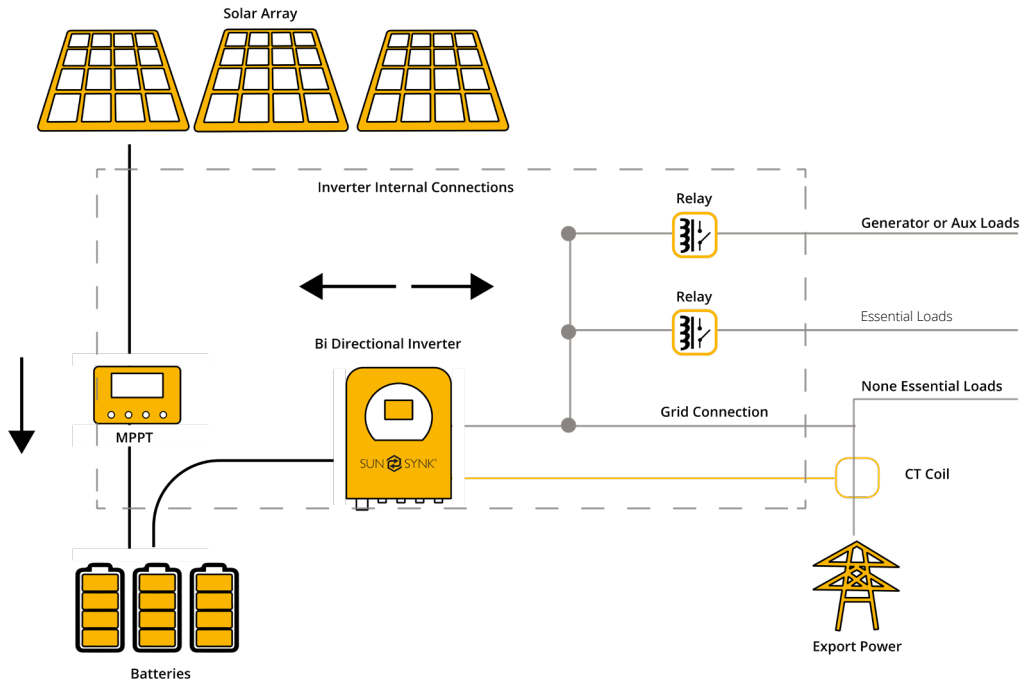

**Setup Page**

To access Settings, click on the gear icon on the right top of the navigation menu.



**Settings** SUN SYNK 03/03/2023 15:35:13

|                |                 |                    |                    |
|----------------|-----------------|--------------------|--------------------|
|                |                 |                    |                    |
| <b>BASIC</b>   | <b>BATTERY</b>  | <b>GRID</b>        | <b>SYSTEM MODE</b> |
|                |                 |                    |                    |
| <b>ADVANCE</b> | <b>AUX LOAD</b> | <b>FAULT CODES</b> | <b>LI BMS</b>      |

ID:2208036022 F      COMM: E42A - MCU:3382-1515

**What this page displays:**

- Serial number.
- Software version.
- Time, Date, and MCU.

**What you can do from this page:**

- Access the Basic Setup Page (press the BASIC icon).
- Access the Battery Setup Page (press the BATTERY icon).
- Access the Grid Setup Page (press the GRID icon).

- Access the real-time programmable timer/system mode (press the SYSTEM MODE icon).
- Access the advanced settings such as Paralleling and Wind Turbine (press the ADVANCE icon).
- Access the auxiliary load/smart load settings (press the AUX LOAD icon).
- Access the fault code register (press the FAULT CODES icon).
- Set up Li BMS (press the LI BMS icon).

# Basic Setup

## Set Time (Clock)

To set time, click on the BASIC icon and then on 'Time'

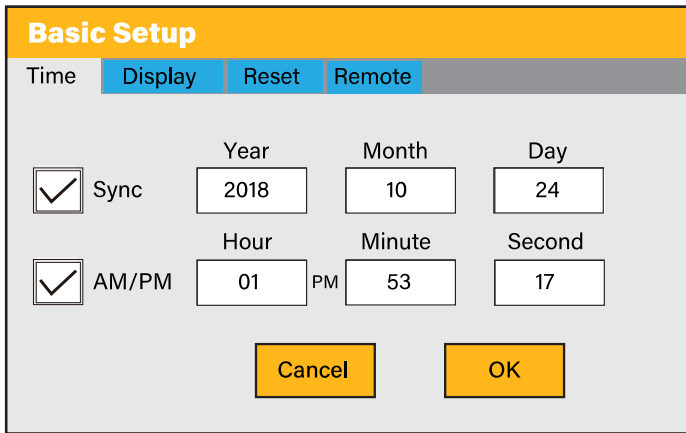

### What this page displays:

- Time.
- Date.
- AM/PM.

### What you can do from this page:

- Adjust / set time.
- Adjust / set date.
- Adjust / set AM/PM.

### How to set up:

- Touch the screen on the box you wish to change.
- Change the number (increase/decrease) using the UP and DOWN buttons.
- Press OK to set the changes.

## Set Company Name / Beeper / Auto dim

To set company name click on the BASIC icon and then on 'Display'.

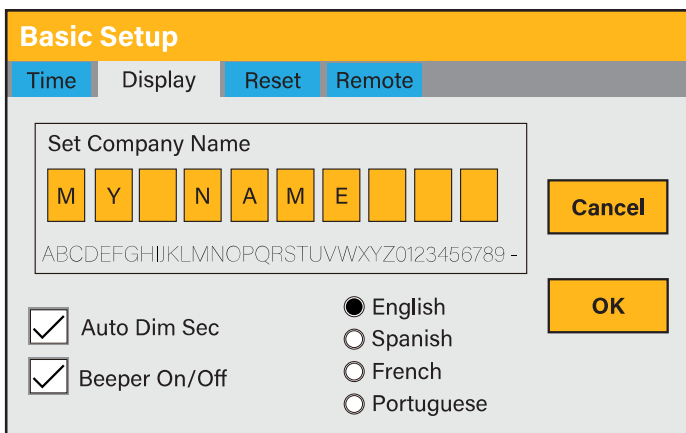

### What this page displays:

- Beeper status (ON/OFF).
- Installers names.

### What you can do from this page:

- Set up your company name.
- Switch the beeper ON or OFF.
- Set the LCD backlight to auto dim.

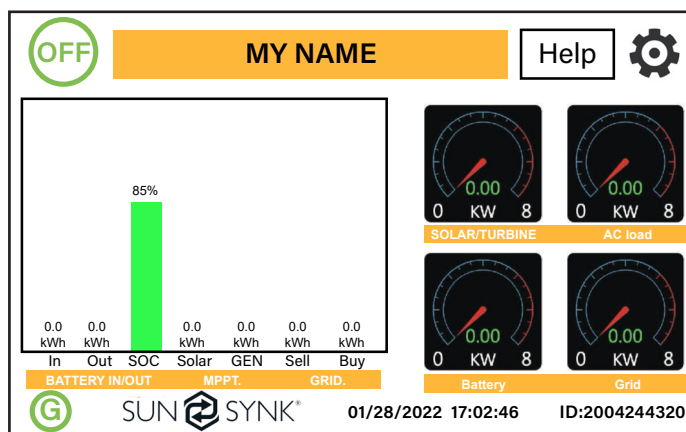

### How to change the name:

Change the letters in each box by moving the arrows up and down and then select OK. This will change the name on the home screen.

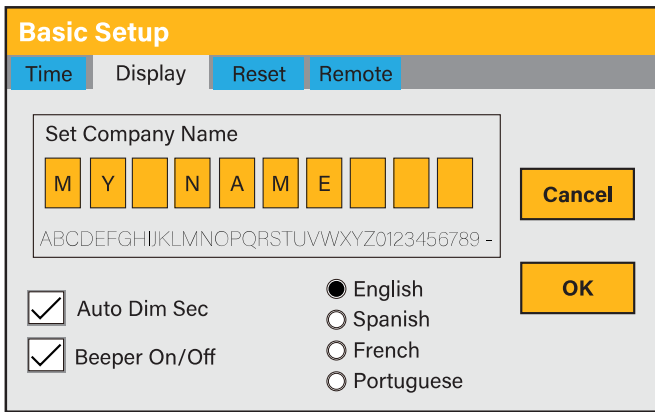

### How to set the auto dim:

Set a number in the auto dim box to dim the LCD after a number of seconds.

### How to turn the beep on or off:

Check or uncheck the beep box and the press OK to configure it as you prefer.

## Factory Reset and Lock Code

To access the Settings, click on the gear icon on the right top of the menu.

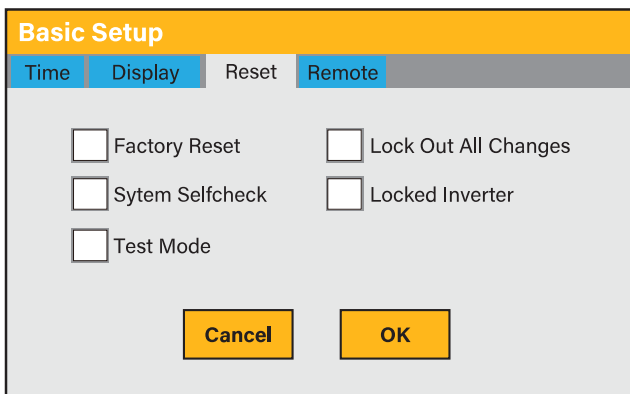
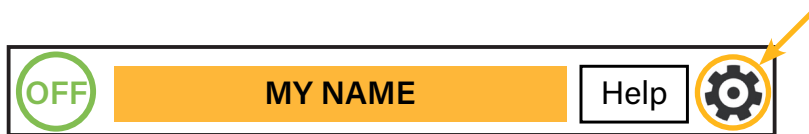

### What this page displays:

- Reset status.
- Whether the 'lock code' is used or not.

### What you can do from this page:

- Reset the inverter to the factory settings.
- System diagnostics.
- Change or set the 'lock code'.

**Factory Reset:** Reset all parameters of the inverter.

**Lock out all changes:** Enable this menu to set parameters before the unit is locked and cannot be reset.

**\*Before performing a successful 'Factory Reset' and locking the systems, the user must enter a password to allow the setting to take place. The password for 'Factory Reset' is 9999 and for lockout is 7777.**

**System self-check:** Allows the user to conduct a system diagnosis. After ticking this item, it needs input the password. The default password is 1234.

**Locked Inverter:** This function is used to lock the inverter completely so no access can be gained. It will ask for a 5-digit code that only the Sunsynk Technical staff can assist with.

**Test mode (only for engineers):** For engineers to conduct tests.

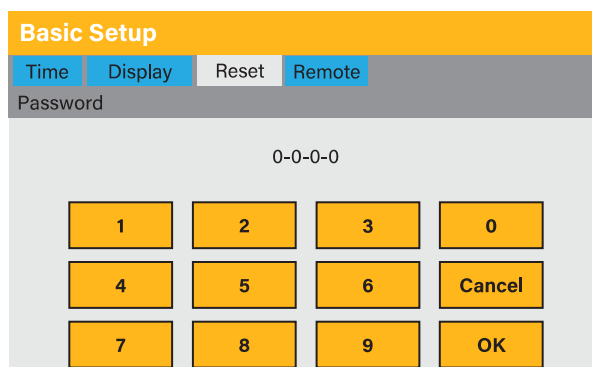

## Inverter Remote Control

To control the inverter remotely, tick the box that allows it.

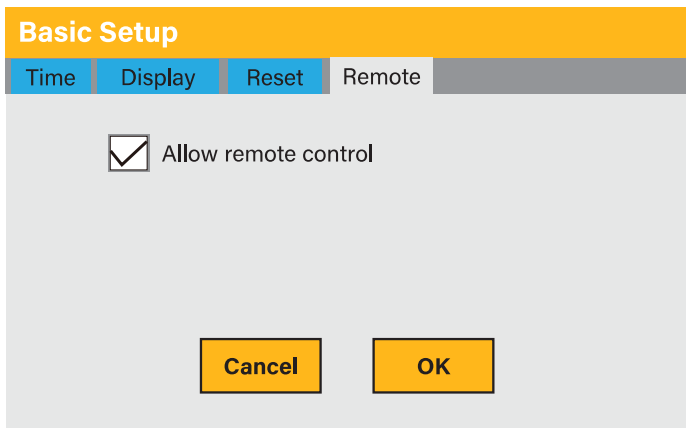

### What this page displays:

- Remote control option.

### What you can do from this page:

- Allows remote control of the inverter.

## Battery Setup Page

To configure battery settings, click on the BATTERY icon and then on 'Batt type'.

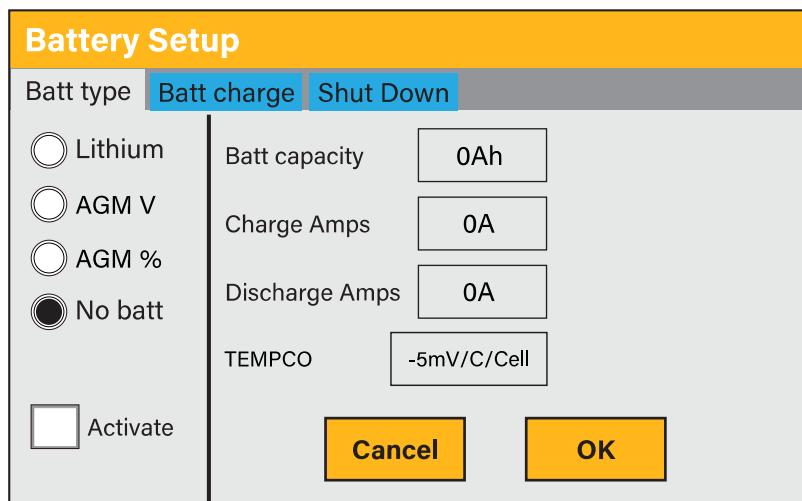

### What this page displays:

- **Lithium:** This is BMS protocol. Please reference the document (Approved Battery).
- **AGM V:** Use battery voltage for all settings (V).
- **AGM %:** Use battery SOC for all settings (%).
- **No batt:** Tick this box if no battery is connected to the system. If it's ticked and the CT coil is connected, the inverter operates as a grid-tied inverter.
- **Battery capacity in (Ah):** For non-BMS-batteries the range allowed is 0-2000Ah, while for lithium-ion, the inverter will use the capacity value of the BMS.
- **Charge/Discharge Amps:** The Max battery charge/discharge current (0-190A for 8kW model, 0-210A for 10kW model, 0-240A for 12kW model).
- **Active battery:** This feature will help recover a battery that is 100% discharged by slowly changing from the solar array. Until the battery reaches a point where it can change normally.
- **TEMPCO settings:** The temperature coefficient is the error introduced by a change in temperature.





## NOTE:

### Recommended:

AGM and Flooded: Ah battery size x 20% = Charge/Discharge amps.

Lithium: Ah battery size x 50% = Charge/Discharge amps.

Gel: follow manufacturer's instructions.

## Generator & Battery Page

To configure battery charging settings, click on the BATTERY icon and then on 'Batt Charge'.

**Battery Setup**

Batt type | Batt charge | Shut Down

Amps: 40A | 5A

Gen Charge |  Grid Charge

Gen Signal |  Grid Signal

Signal ISLAND MODE | Force OFF

Gen Force | Cancel | OK

Float V: 55.2V

Absorption V: 57.6V

Equalization V: 58.8V

90 days

2.3 hours

### What this page displays:

- **Amps:** Charge rate of 40A from the attached generator in Amps.
- **Grid Amps:** Current that the grid charges the battery.
- **Grid Charge:** It indicates that the grid will charge the battery.
- **Grid Signal:** This indicates when the grid should no longer charge the battery.
- **Gen Charge:** Uses the GEN input of the system to charge the battery bank from an attached generator.
- **Gen Signal:** Normally open (NO) relay that closes when the Gen Start signal state is active.
- **Gen Force:** When the generator is connected, it is forced to start without meeting other conditions.
- **Force OFF:** This is to force the generator to switch off.
- **Signal ISLAND MODE:** When "signal island mode" is checked and the inverter connects the grid, the ATS port voltage will be 0. When "signal island mode" is checked and the inverter is disconnected from the grid, the ATS port voltage will output 230Vac. This feature and outside NO type relay can realize N and PE disconnection or bond.
- **Float V:** The voltage at which a battery is maintained after being fully charged. Float V for an AGM battery is 55.20V.

- **Absorption V:** The level of charge that can be applied without overheating the battery. Absorption V is for an AGM battery is 57.60V.
- **Equalization V:** Equalizing charge/overcharge to remove sulphate crystals that build up on the plates over time on lead-acid batteries. Equalization V for an AGM battery is 58.80V.



**NOTE:**

Do not alter these settings too often on the same battery, as it may damage the battery.

**Recommended battery settings:**

| Battery Type | Absorption Stage                  | Float Stage   | Voltage (every 30 days 3hr) |
|--------------|-----------------------------------|---------------|-----------------------------|
| AGM (or PCC) | 14.2V (57.6V)                     | 13.4V (53.6V) | 14.2V (57.6V)               |
| Gel          | 14.1V (56.4V)                     | 13.5V (54.0V) |                             |
| Wet          | 14.7V (59.0V)                     | 13.7V (55.0V) | 14.7V (59.0V)               |
| Lithium      | Follow its BMS voltage parameters |               |                             |

A generator can either be connected to the Grid side or to the Gen connection. When connected to the Grid Input, the inverter will consider the power coming from the generator as 'Grid Supply'. Users should ensure this power goes to the LOAD only and should not be exported to other outlets, as this will damage the generator.

If the generator is connected to the inverter and a generating signal exists, the inverter will switch 100% of the load to the generator and then slowly increase the charging currents to the batteries. Therefore, the generator must be able to supply both the charge current and the total load current.

The generator can be controlled via a relay with a set of dry-contacts to enable remote control. The current on the contacts is limited to approximately 1Amp 12V.

Below is a simple reference circuit of an auto-start system that can auto-start generators on a boat. (Sunsynk will be releasing a new OS E406 ( Auto-Start ) for better generator control).

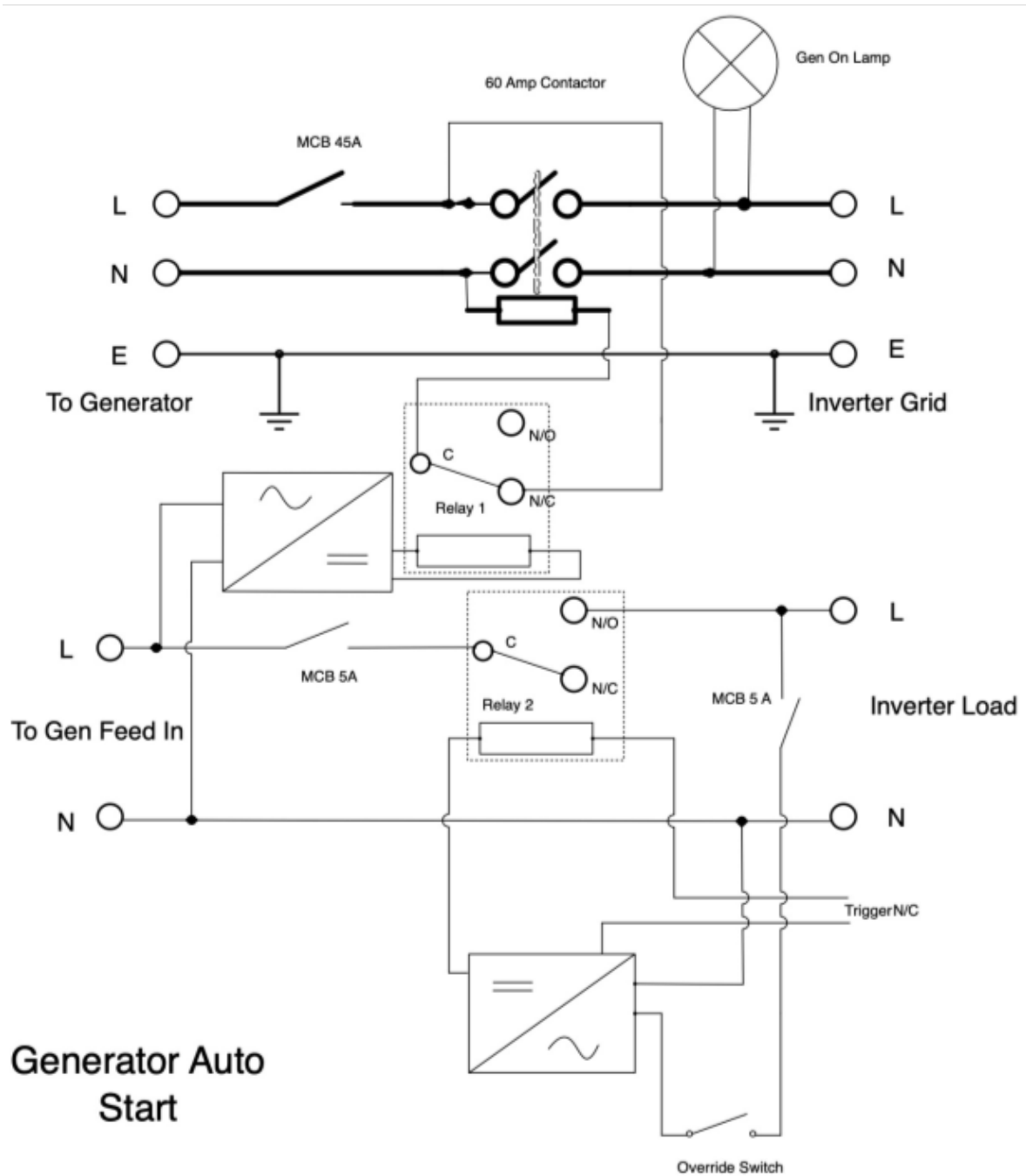

## Battery Discharge Page

To configure inverter's shut-down settings, click on the BATTERY icon and then on 'Shut Down'.

**Battery Setup**

| Batt type | Batt charge | Shut Down                |                          |
|-----------|-------------|--------------------------|--------------------------|
| Shut Down | 20%         | <input type="checkbox"/> | Low PowerMode < Low Batt |
| Low Batt  | 20%         | <input type="checkbox"/> | Low Noise Mode           |
| Restart   | 40%         |                          |                          |

Cancel
OK

### What this page displays:

- **Shutdown 20%:** It indicates the inverter will shutdown if the SOC is below this value.
- **Low Batt 20%:** It indicates the inverter will alarm if the SOC below this value.
- **Restart 40%:** Battery voltage at 40% AC output will resume.
- **Low Power Mode<Low Batt:** If selected and when battery SOC is less than the “Low Bat” value, the self-consumption power of the inverter will be from the grid and battery simultaneously. If unselected, the self-consumption power of the inverter will be mainly from the grid.
- **Low Noise Mode:** Low noise mode is used to change the switching frequency of the IGBTs from 15kHz to 20kHz, we did this because 15kHz was in the audible range still meaning that people with great hearing could hear a high pitch noise when using other electrical products, the inverter interacted with it on the AC line with electrical noise.

### What you can do from this page:

- Adjust battery shut down (voltage or %)
- Adjust low battery warning (voltage or %)
- Adjust restart (voltage or %)



#### NOTE:

Activating Shutdown causes the inverter to enter standby-mode. It does not entirely shut down the inverter. Total shutdown occurs at voltages below 19V.

The voltage displayed on the Sunsynk Parity Inverter will vary depending on whether the inverter is charging or discharging the batteries.

SUNSYNK PARITY INVERTER CHARGE VOLTAGE

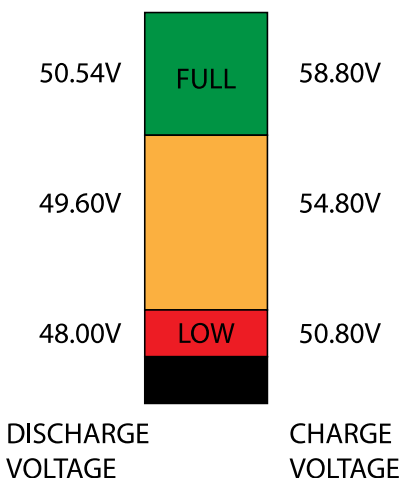

#### Since the batteries are 48V, the figure on the left is x4:

- Fully Charged 50.54V (Discharge Mode)
- Fully Charged 58.80V (Charge Mode)
- 75% Charged 49.60V (Discharge Mode)
- 75% Charged 54.80V (Charge Mode)
- 25% Charged 48.00V (Discharge Mode)
- 25% Charged 50.80V (Charge Mode)
- Completely Discharged 47.50V

Setting the cut-off higher is better for the batteries.

The batteries recommended for use with the Sunsynk systems are AGM Lead Acid or Lithium Battery Banks. At its core, an AGM is still a lead-acid battery. AGM stands for Absorbent Glass Mat, which refers to the technology these devices use to create power. This fiberglass mat sits between the positive and negative lead plates of your battery. Then, as the name suggests, it absorbs and holds the battery acid. That way, it doesn't freely flow around the battery.

## State of Charge

**Bulk:** The bulk charge is the first stage of a battery's charging process, where the charger identifies the battery and its needs and then applies a high voltage to do the bulk of the charging. It involves about 80% of the recharge. The properly sized charger will give the battery as much current as it will accept up to charger capacity (25% of battery capacity in Amp hours).

**Absorption:** To fully charge a battery, a period of charging at a relatively high voltage is needed. This period of the charging process is called absorption. This occurs when the charging of a battery has reached 80% of its capacity. The remaining charge equals 20% approximately. It makes the charger hold the voltage at the charger's absorption voltage (between 14.1 VDC and 14.8 VDC, depending on charger set points) and decreases the current until the battery is fully charged.

**Float:** The charging voltage is reduced to between 13.0 VDC and 13.8 VDC and held constant, while the current is reduced to less than 1% of battery capacity. This mode can be used to maintain a fully charged battery indefinitely.

**Equalisation:** This is essentially a controlled overcharge that occurs at the end of the Bulk mode and the absorption phase and is called the 'equalisation voltage'. However, technically, this phase has another function. Higher capacity wet (flooded) batteries sometimes benefit from this procedure, particularly the physically tall batteries. The electrolyte in a wet battery can stratify over time if not cycled occasionally. In equalisation, the voltage is brought up above the typical peak charging voltage well into the gassing stage and maintained for a fixed (but limited) period. This stirs up the chemistry in the entire battery, 'equalising' the strength of the electrolyte and knocking off any loose sulphating that may be on the battery plates.

## Setting Up a Lithium Battery

To set up a lithium-ion battery, click on the BATTERY icon and visit the 'Batt Type' column.

**Battery Setup**

Batt type | **Batt charge** | Shut Down

Lithium  
 AGM V  
 AGM %  
 No batt

Activate

Batt capacity: 0Ah  
Charge Amps: 0A  
Discharge Amps: 0A

CAN  
 RS485  
Protocol: 0  
 BMS\_Err\_Stop

Cancel OK

### What this page displays:

- This information will only display if the 'Lithium' option is selected under 'Batt Type'.
- The type of communication protocol.
- Approved batteries.
- **BMS\_Err\_Stop:** When it is active, if the battery BMS fails to communicate with inverter, the inverter will stop working and report fault.

### What you can do from this page:

- Set up your Lithium-ion battery.

After installing a lithium battery, check the communications page by clicking on the 'Li BMS' icon to see if the BMS information is visible. Suppose some information is not displayed correctly (it should look like the diagram below), then there will be a communication error.

| Li BMS <span style="float: right;">Help ?</span> |              |
|--|--------------|
| Sum Data   | Details Data |
| Battery Voltage: 53.06V                          |              |
| Battery Current: -1A                             |              |
| Battery Temp: 22.0C                              |              |
| Total SOC: 85%                                   |              |
| Total SOH: 100%                                  |              |
| Battery Chage Voltage: 58.0V                     |              |
| Charge Current Limit: 50A                        |              |
| Discharge Current Limit: 50A                     |              |

| Li BMS <span style="float: right;">Help ?</span> |          |        |       |       |              |        |       |       |
|--|----------|--------|-------|-------|--------------|--------|-------|-------|
|  | Sum Data |        |       |       | Details Data |        |       |       |
|  | Volt     | Curr   | Tem   | SOC   | Energy       | Charge |       | Fault |
|  |          |        |       |       |              | Volt   | Curr  |       |
| 1  | 50.31V   | 19.70A | 29.6C | 33.0% | 26.0Ah       | 0.0V   | 0.0A  | 0 0 0 |
| 2  | 50.38V   | 31.70A | 37.6C | 51.0% | 25.5Ah       | 53.2V  | 25.0A | 0 0 0 |
| 3  | 50.35V   | 25.10A | 29.9C | 52.0% | 6.0Ah        | 53.2V  | 25.0A | 0 0 0 |
| 4  | 50.37V   | 30.70A | 32.1C | 12.0% | 26.0Ah       | 0.0V   | 0.0A  | 0 0 0 |
| 5  | 50.35V   | 00.00A | 30.6C | 48.0% | 32.0Ah       | 0.0V   | 0.0A  | 0 0 0 |
| 6  | 50.36V   | 15.40A | 30.6C | 52.0% | 39.1Ah       | 0.0V   | 0.0A  | 0 0 0 |
| 7  | 00.00V   | 00.00A | 0.0C  | 00.0% | 00.0Ah       | 0.0V   | 0.0A  | 0 0 0 |
| 8  | 50.38V   | 19.30A | 31.0C | 52.0% | 25.5Ah       | 0.0V   | 0.0A  | 0 0 0 |
| 9  | 50.39V   | 16.30A | 30.6C | 52.0% | 26.0Ah       | 0.0V   | 0.0A  | 0 0 0 |
| 10   | 00.00V   | 00.00A | 0.0C  | 00.0% | 00.0Ah       | 0.0V   | 0.0A  | 0 0 0 |
| 11   | 00.00V   | 00.00A | 0.0C  | 00.0% | 00.0Ah       | 0.0V   | 0.0A  | 0 0 0 |
| 12   | 00.00V   | 00.00A | 0.0C  | 00.0% | 00.0Ah       | 0.0V   | 0.0A  | 0 0 0 |
| 13   | 00.00V   | 00.00A | 0.0C  | 00.0% | 00.0Ah       | 0.0V   | 0.0A  | 0 0 0 |
| 14   | 00.00V   | 00.00A | 0.0C  | 00.0% | 00.0Ah       | 0.0V   | 0.0A  | 0 0 0 |
| 15   | 00.00V   | 00.00A | 0.0C  | 00.0% | 00.0Ah       | 0.0V   | 0.0A  | 0 0 0 |

Therefore, if a communication error occurs:

1. Check that your data cable is the correct type.
2. Check that the data cable is plugged into the correct sockets. Usually, RS485 is employed, but some battery manufacturers use others.



**NOTE:**

With some types of lithium batteries, the BMS cannot be controlled by the Sunsynk inverter. In this case, treat the battery as a lead-acid type and set the charging and discharging protocol following the battery manufacturer's specifications.

It is crucial to refer to the manuals that manufacturers produce for their batteries. That way, the chance of errors occurring during installation is significantly reduced. Below is a list of batteries that have been examined, tested, and approved by Sunsynk.

| Brand      | Model             | 48V Storage Inverter | RS485 or CAN | Inverter Setup | Notes                        |
|------------|-------------------|----------------------|--------------|----------------|------------------------------|
| DYNESS     | B4850             | ✓                    | CAN          | 0              |                              |
|            | POWERBOXF         |                      |              | 0              |                              |
|            | A48100            |                      |              | 0              |                              |
| SunketESS  | LFP5000           | ✓                    | CAN          | 0              |                              |
| Osily      | LFP5KWH/LV        | ✓                    | CAN          | 0              |                              |
| HUBBLE     | AM-2 5.5KW        | ✓                    | CAN          | 0              | CANH = Pin 4<br>CANL = Pin 5 |
|            | AM-5              |                      | CAN          | 0              |                              |
|            | AM-10             |                      | CAN          | 0              |                              |
| SACRED SUN | SSIF2P15S48100C   | ✓                    | RS485        | 1              | Cut Line 3, 6, 8             |
|            | FCIFP48100A       |                      | RS485        | 1              |                              |
|            | SSIFP48100A       |                      | RS485        | 1              |                              |
| SHOTO      | SDC-Box5(5.12KWH) | ✓                    | CAN          | 0              |                              |

| Brand        | Model                        | 48V Storage Inverter | RS485 or CAN | Inverter Setup | Notes  |
|--------------|------------------------------|----------------------|--------------|----------------|--|
| SolarMD      | SS4074                       | ✓                    | CAN          | 0              | To be used with V2 Logger<br><a href="http://solarmd.co.za/inverter-compatibility-solarmd/sunsynk-and-solar-md/">http://solarmd.co.za/inverter-compatibility-solarmd/sunsynk-and-solar-md/</a> |
|              | SS4037                       |                      |              | 0              |  |
|              | SS202                        |                      |              | 0              |  |
| PYLON        | US2000B                      | ✓                    | CAN          | 0              |  |
|              |                              |                      | RS485        | 12             |  |
|              | US3000                       |                      | CAN          | 0              |  |
|              |                              |                      | RS485        | 12             |  |
|              | US2000C                      |                      | CAN          | 0              |  |
|              |                              |                      | RS485        | 12             |  |
|              | US3000C                      |                      | CAN          | 0              |  |
|              |                              |                      | RS485        | 12             |  |
|              | UP5000                       |                      | CAN          | 0              |  |
|              |                              |                      | RS485        | 12             |  |
|              | US5000                       |                      | CAN          | 0              |  |
| RS485        |                              | 12                   |              |                |  |
| Force L1     | CAN                          | 0                    |              |                |  |
|              | RS485                        | 12                   |              |                |  |
| Force L2     | CAN                          | 0                    |              |                |  |
|              | RS485                        | 12                   |              |                |  |
| UZ ENERGY    | L051100-A                    | ✓                    | CAN          | 0              |  |
|              | L051100-A1                   |                      | CAN          | 0              |  |
|              | L051100-B                    |                      | CAN          | 0              |  |
|              | L051100-D                    |                      | CAN          | 0              |  |
| GenixGreen   | ESS-5120                     | ✓                    | RS485        | 6              |  |
|              | ESS-10240                    |                      | RS485        | 6              |  |
|              | ESS-BOX2                     |                      | RS485        | 6              |  |
|              | ESS-BOX3                     |                      | RS485        | 6              |  |
|              | ESS-BOX4                     |                      | RS485        | 6              |  |
|              | ES-BOX2                      |                      | RS485        | 6              |  |
|              | ES-BOX5                      |                      | RS485        | 6              |  |
| ES-BOX12     | RS485                        | 6                    |              |                |  |
| Sunwoda      | H4850M                       | ✓                    | CAN          | 0              |  |
|              | SunESS                       |                      | CAN          | 0              |  |
|              | Atrix                        |                      | CAN          | 0              |  |
| APIUM        | AP-5                         | ✓                    | CAN          | 0              |  |
|              | APR-5                        |                      | CAN          | 0              |  |
| VISION Group | V-LFP51.2V100Ah-5KW          | ✓                    | CAN          | 13             |  |
|              | VLFP51.2V200Ah-5KW           |                      | CAN          | 13             |  |
| Alpha Ess    | M4856-P                      | ✓                    | CAN          | 0              |  |
|              | SMILE BAT                    |                      | CAN          | 0              |  |
| BYD          | BYD Battery-Box LV Flex Lite | ✓                    | CAN          | 0              |  |

| Brand              | Model   | 48V Storage Inverter | RS485 or CAN | Inverter Setup | Notes                        |
|--------------------|---|----------------------|--------------|----------------|------------------------------|
| Greenrich          | AU5500(UP3686)  | ✓                    | CAN          | 0              |                              |
|                    | AU7500(UP5000)  |                      |              | 0              |                              |
|                    | AU9000(UP6100)  |                      |              | 0              |                              |
|                    | AW7500(WM5000)  |                      |              | 0              |                              |
|                    | SSRE-EU10K  |                      |              | 0              |                              |
| TOPBAND            | TB51100F-T110   | ✓                    | CAN          | 0              |                              |
|                    | TB51120-T110  |                      | CAN          | 0              |                              |
| Weco               | 4K4 LV  | ✓                    | CAN          | 0              |                              |
|                    | 5K3 LV  |                      | CAN          | 0              |                              |
| GSL ENERGY         | GSL051100A-B-GBP2                                     | ✓                    | CAN          | 0              |                              |
|                    | GSL051200A-B-GBP2                                     |                      | CAN          | 0              |                              |
|                    | GSL051280A-B-GBP2                                     |                      | CAN          | 0              |                              |
|                    | ZnP48100ESA1  |                      | CAN          | 0              |                              |
|                    | GSL-51-100  |                      | CAN          | 0              |                              |
|                    | GSL-51-200  |                      | CAN          | 0              |                              |
| DOWELL             | IPACK C3.3  | ✓                    | CAN          | 0              |                              |
|                    | IPACK C6.5  |                      | CAN          | 0              |                              |
|                    | IPACK C10   |                      | CAN          | 0              |                              |
| Giter              | G2500-48V   | ✓                    | CAN          | 0              |                              |
|                    | G5040-48V   |                      | CAN          | 0              |                              |
| CF Energy          | CFE2400   | ✓                    | CAN          | 0              |                              |
|                    | CFE5100   |                      | CAN          | 0              |                              |
|                    | CFE5100S  |                      | CAN          | 0              |                              |
| Deye               | SUNB-5.0-G01-48-PC<br>SE-G5.1 PRO/AI-W5.1/<br>RW-M6.1 | ✓                    | CAN          | 0              |                              |
| AOBOET             | Uhome-LFP 5000  | ✓                    | CAN          | 0              |                              |
|                    | Uhome-LFP 2400  |                      | CAN          | 0              |                              |
| Wattsonic          | Li-LV battery series                                  | ✓                    | RS485        | 14             |                              |
| KODAK              | FL5.2   | ✓                    | CAN          | 0              |                              |
| Fox ess            | LD-48100P   | ✓                    | RS485        | 1              |                              |
| PYTES Energy       | E-BOX 48100R  | ✓                    | CAN          | 0              |                              |
| BST                | MD48-100  | ✓                    | CAN          | 0              |                              |
|                    | MD48-50   |                      | CAN          | 0              |                              |
| Rosen Solar Energy | LFP48V200AH   | ✓                    | CAN          | 0              |                              |
|                    | LFP51.2V200AH   |                      | CAN          | 0              |                              |
| Highstart          | HSD4870   | ✓                    | CAN          | 0              |                              |
| BALANCELL          | P26   | ✓                    | CAN          | 0              |                              |
|                    | P27   |                      | CAN          | 0              |                              |
| Photon             | PTN-BAT-05K-WM-LFP<br>(5KWh / 100Ah)                  | ✓                    | CAN          | 0              | CANH = Pin 4<br>CANL = Pin 5 |



| Brand  | Model  | 48V Storage Inverter | RS485 or CAN | Inverter Setup | Notes |
|--|--|----------------------|--------------|----------------|-------|
| ZRGP   | ZR-FC48100-1630J1                            | ✓                    | CAN          | 0              |       |
|  | ZR-FS4850-160SJ1                             |                      | CAN          | 0              |       |
|  | ZR-FS48100-160SJ1                            |                      | CAN          | 0              |       |
|  | ZR-PBX1                                      |                      | CAN          | 0              |       |
| UFO  | U-P48200-7                                   | ✓                    | CAN          | 0              |       |
|  | U-P48100-7                                   |                      | CAN          | 0              |       |
|  | U-P48150-1                                   |                      | CAN          | 0              |       |
| DMEGC  | L01-48100                                    | ✓                    | CAN          | 0              |       |
|  | L02-48200                                    |                      | CAN          | 0              |       |
| Robuste  | LR48100                                      | ✓                    | CAN          | 0              |       |
|  | LR48200                                      |                      | CAN          | 0              |       |
| Soluna   | 4K Pack                                      | ✓                    | CAN          | 0              |       |
|  | 5K Pack                                      |                      | CAN          | 0              |       |
|  | EOS-5K Pack                                  |                      | CAN          | 0              |       |
| REVOV  | R100   | ✓                    | CAN          | 0              |       |
| PAND   | Powerfree Rack                               | ✓                    | CAN          | 0              |       |
|  | Powerfree Cube                               | ✓                    | CAN          | 0              |       |
| CLIS (Zhong-neng Lithium Battery Technology Taizhou Co., Ltd.) | Enerhi-M Series                              | ✓                    | CAN          | 0              |       |
| LBSA   | LBSA 51.2V/100Ah                             | ✓                    | CAN          | 0              |       |
| Freedomwon   | Freedomwon Lite Commercial 52V and LV Models | ✓                    | CAN          | 0              |       |
| GSO  | GBP48  | ✓                    | CAN          | 0              |       |
| Sunketess  | LFP5000                                      | ✓                    | CAN          | 0              |       |
| Vestwoods  | VT Series                                    | ✓                    | CAN          | 0              |       |
|  | VE Series                                    |                      | CAN          | 0              |       |
| Green Solutions Inc.   | HOME E10                                     | ✓                    | CAN          | 0              |       |
| nRuiT Energy   | PowerPorter 5.0/9.0/10.0/12.0/15.0           | ✓                    | CAN          | 0              |       |
| Far East Battery   | FEB LV Series                                | ✓                    | CAN          | 0              |       |
| GEN2   | Gen2 P48200-7                                | ✓                    | CAN          | 0              |       |
|  | Gen2 P48100-7                                |                      | CAN          | 0              |       |
|  | Gen2 P48150-1                                |                      | CAN          | 0              |       |
| LEMAX  | LM-JW-51.2V100Ah                             | ✓                    | CAN          | 0              |       |
|  | LM-JW-51.2V200Ah                             |                      | CAN          | 0              |       |

| Brand                        | Model                      | 48V Storage Inverter | RS485 or CAN | Inverter Setup | Notes   |
|------------------------------|----------------------------|----------------------|--------------|----------------|---|
| COOLI                        | CLR5KWH                    | ✓                    | CAN          | 0              |   |
|                              | CLW5KWH                    |                      | CAN          | 0              |   |
|                              | CLR10KWH                   |                      | CAN          | 0              |   |
|                              | CLW10KWH                   |                      | CAN          | 0              |   |
|                              | CLH10KWH                   |                      | CAN          | 0              |   |
|                              | ESS10240                   |                      | CAN          | 0              |   |
| VOLTA                        | VOLTA STAGE1               | ✓                    | CAN          | 0              |   |
|                              | VOLTA STAGE2               |                      | CAN          | 0              |   |
|                              | VOLTA STAGE3               |                      | CAN          | 0              |   |
|                              | VOLTA STAGE4               |                      | CAN          | 0              |   |
| EVO                          | EVO 5.7KWH 48V-120Ah       | ✓                    | CAN          | 0              |   |
| Yoshopo                      | BB-LFP-100Ah-P             | ✓                    | CAN          | 0              |   |
| BNP                          | 51.2V 100Ah                | ✓                    | CAN          | 0              |   |
| Shanghai Green Tech Co.,Ltd. | GTEM-48V2500               | ✓                    | RS485        | 12             |   |
| Unipower                     | UPI.FP4845                 | ✓                    | RS485        | 15             |   |
| LD                           | LD-100P210J                | ✓                    | RS485        | 17             |   |
| Felicity                     | LPBF Series                | ✓                    | RS485        | 12             |   |
|                              | LPBA-OL Series             |                      | RS485        | 12             |   |
|                              | LPBA-IL Series             |                      | RS485        | 12             |   |
| BSL                          | B-LFP51.2V 100Ah           | ✓                    | CAN          | 0              | Float voltage 54.5V<br>Absorption V 55.00V<br>Disable equalisation 0 Days<br>Shutdown 20%<br>Low Batt 35%<br>Restart 50%        |
|                              | B-FLP51.2V 125Ah           |                      |              |                |   |
|                              | B-LFP48-130E 51.2V 130Ah   |                      |              |                |   |
|                              | B-LFP48-160E 51.2V 160Ah   |                      |              |                |   |
|                              | B-LFP51.2V 200Ah Powerwall |                      |              |                |   |
| Enersol Lithium              | 48-100                     | ✓                    | CAN          | 0              | BMS cable – straight RJ45 cable ( no need to change pin outs on cable)<br><br>Dip Switch settings is 1000 ( for single battery) |
|                              | 51-100                     |                      | CAN          | 0              |   |
|                              | 51-200                     |                      | CAN          | 0              |   |
|                              | 51-100WM                   |                      | CAN          | 0              |   |
|                              | 51-200WM                   |                      | CAN          | 0              |   |
| Blue Nova Rackpower          | RacPower BN52-100-5.2K BP  | ✓                    | CAN          | 0              |   |
|                              | RacPower BN52-100-5.2K DU  |                      | CAN          | 0              |   |

| Brand                 | Model               | 48V Storage Inverter | RS485 or CAN | Inverter Setup | Notes   |
|-----------------------|---------------------|----------------------|--------------|----------------|---|
| Blue Nova HC          | BN52V-280-14.5K HC  | ✓                    | CAN          | 0              | Can be used with or without BMAC  |
|                       | BN52V-560-29K HC    |                      | CAN          | 0              | <a href="https://www.blunova.co.za/wp-content/uploads/2015/11/BN-User-Manual-HC_v102.pdf">https://www.blunova.co.za/wp-content/uploads/2015/11/BN-User-Manual-HC_v102.pdf</a> |
|                       | BN52V-840-43.6K HC  |                      | CAN          | 0              |   |
|                       | BN52V-1120-58.2K HC |                      | CAN          | 0              | CANH = Pin 7  |
|                       | BN52V-1400-72.8K HC |                      | CAN          | 0              | CANL = Pin 8  |
| Blue Nova Rack Series | BN52V-840-43.6K BR  | ✓                    | CAN          | 0              | BlueNova-BMAC-Manual-v4.pdf   |
|                       | BN52V-1120-58.2K BR |                      | CAN          | 0              |   |



**NOTE:**

Ensure the cable is thick enough to support the current and that the connected fuses are of the correct rating per the battery manufacturers' recommendations.

# Program Charge & Discharge Times

To set 'Charge' and 'Discharge' times, click on the 'System Mode' icon after clicking on the gear icon.

**System Mode**

System 1 | **System 2**

| Time Start | Time End | Power | SOC/V | Grid                                | Gen                                 |
|------------|----------|-------|-------|-------------------------------------|-------------------------------------|
| 01:00      | 05:00    | 8000  | 100%  | <input checked="" type="checkbox"/> | <input checked="" type="checkbox"/> |
| 05:00      | 09:00    | 8000  | 100%  | <input checked="" type="checkbox"/> | <input checked="" type="checkbox"/> |
| 09:00      | 13:00    | 8000  | 100%  | <input checked="" type="checkbox"/> | <input checked="" type="checkbox"/> |
| 13:00      | 17:00    | 8000  | 100%  | <input checked="" type="checkbox"/> | <input checked="" type="checkbox"/> |
| 17:00      | 21:00    | 8000  | 100%  | <input checked="" type="checkbox"/> | <input checked="" type="checkbox"/> |
| 21:00      | 01:00    | 8000  | 100%  | <input checked="" type="checkbox"/> | <input checked="" type="checkbox"/> |

User Timer

Cancel

OK

**System Mode**

**System 1** | System 2

8000W Power  Grid Peak shaving

1  Use Export Controller  Priority Load

2  Solar Export

3  Limit to Load Only

4  20W Grid Trickle Feed

5  8000W Inverter Power Limiter

Cancel

OK

## What this page displays:

- Use Export Controller:** Tick this box to not export power back to the grid (the CT coil will detect power flowing back to the grid and will reduce the power of the inverter only to supply the local load).
- Solar Export:** Tick this box if you wish to export your solar power back to the grid.
- Limit to Load Only:** Tick this box if you only want to supply power to the load side of the inverter.
- Grid Trickle Feed:** Is the amount of power flowing from the grid to the inverter. Set this value to '20 - 100W' to instruct the inverter to always take the prescribed amount of power from the grid to minimise the tripping of sensitive pre-paid electricity meters if 'Reverse Power Detection' occurs.
- Inverter Power Limiter:** This controls the maximum overall power, both to the 'Load' and 'Grid' ports combined. It is set to Low if an 'over-current' fault occurs.
- Priority Load:** Tick this box if you wish to set the solar panels to give power to the 'Load'. If you untick this box, the solar will send power to charge the batteries.

7. **Grid peak shaving:** When this is selected, the grid output power will be limited within the set value. If the load power exceeds the allowed value, it will take PV energy and stored battery energy to supplement. If there is not enough PV energy or stored energy to meet the load requirement, grid power will increase to meet the load needs.

**What you can do from this page:**

- Set a real time to start and stop charging or discharging the battery.
- Choose to charge the battery from the grid or generator.
- Limit export power to the grid.
- Set the unit to charge the battery from the grid or generator ticking 'Grid' or 'Gen' and set what times this needs to occur.
- Set the time to discharge the unit to the load or export to the grid by unticking 'Grid' and 'Gen'.
- **If nothing ticked:** This Mode allows the hybrid inverter to sell back any excess power produced by the solar panels to the grid. If the use time is active, the battery energy can also be sold into the grid. The PV energy will be used to power the load and charge the battery, and then excess energy will flow to the grid. Power source priority for the load is as follows:
  1. Solar Panels.
  2. Grid.
  3. Batteries (until programable % discharge is reached).

**Zero Export + Limit To Load Only:** The hybrid inverter will only provide power to the backup load connected. The hybrid inverter will neither provide power to the home load nor sell power to the grid. The built-in CT will detect power flowing back to the grid and will reduce the power of the inverter only to supply the local load and charge the battery.

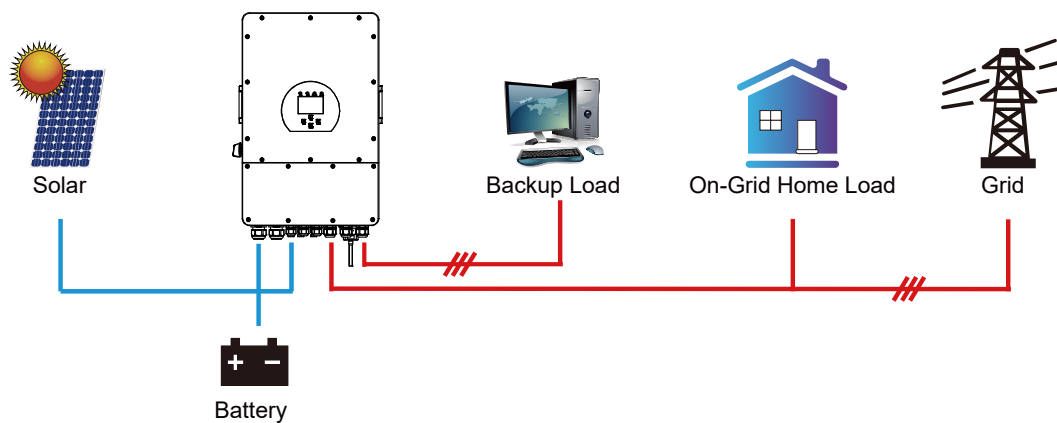

**ZeroExport:** The hybrid inverter will not only provide power to the backup load connected but also give power to the home load connected. If PV power and battery power are insufficient, it will take grid energy as a supplement. The hybrid inverter will not sell power to the grid. In this mode, a CT is needed. For the installation method of the CT, please refer to the chapter "CT Connection". The external CT will detect power flowing back to the grid and will reduce the power of the inverter only to supply the local load, charge the battery, and home load.

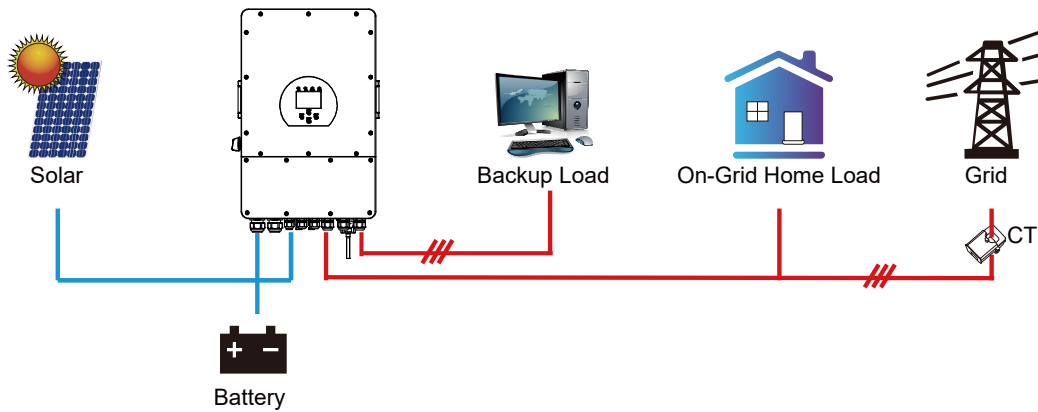

**Example:**

This example shows the battery being charged up to 100% by both the Grid and Solar PV from 8 a.m. to 11 a.m. and then being able to supply up to 4kW of battery-power to the 'essential' loads from the 'Load' Port until the battery SOC drops to 50%.

**System Mode**

System 1 | System 2

| Time Start           | Time End             | Power                | SOC/V                | Grid                                | Gen                      |
|----------------------|----------------------|----------------------|----------------------|-------------------------------------|--------------------------|
| 08:00                | 11:00                | 4000                 | 100%                 | <input checked="" type="checkbox"/> | <input type="checkbox"/> |
| <input type="text"/> | <input type="text"/> | <input type="text"/> | <input type="text"/> | <input type="checkbox"/>            | <input type="checkbox"/> |
| <input type="text"/> | <input type="text"/> | <input type="text"/> | <input type="text"/> | <input type="checkbox"/>            | <input type="checkbox"/> |
| <input type="text"/> | <input type="text"/> | <input type="text"/> | <input type="text"/> | <input type="checkbox"/>            | <input type="checkbox"/> |
| <input type="text"/> | <input type="text"/> | <input type="text"/> | <input type="text"/> | <input type="checkbox"/>            | <input type="checkbox"/> |
| <input type="text"/> | <input type="text"/> | <input type="text"/> | <input type="text"/> | <input type="checkbox"/>            | <input type="checkbox"/> |

User Timer

Cancel

OK

**System Mode**

System 1 | System 2

8000W Power  Grid Peak shaving

Use Export Controller  Priority Load

Solar Export

Limit to Load Only

100W Grid Trickle Feed

5000W Inverter Power Limiter

Cancel

OK

**IMPORTANT** - When charging the batteries from the Grid or Generator, please ensure you have set the correct battery-charging settings on the battery charge as shown in Section 'Battery Setup' Home Page. If the 'User Timer' function is activated then the inverter will use the battery power according to your settings when the Grid is present. If this function is not set, the batteries WILL ONLY be used for backup when there is no utility grid power.

**Example:**

The power produced is supplying the 'Non-Essential Load' while the inverter is set at a maximum power of 8kW (Max Sell Power). The inverter is connected to the grid, but no export is performed. The unit allows small amounts of power to flow from the Grid (100W Zero Export Power) to prevent any back-flow. In this example, the solar PV is prioritised to supply the Load first and then subsequently, charge the battery.

**System Mode**

System 1 | System 2

| Time Start           | Time End             | Power                | SOC/V                | Grid                     | Gen                      |
|----------------------|----------------------|----------------------|----------------------|--------------------------|--------------------------|
| <input type="text"/> | <input type="text"/> | <input type="text"/> | <input type="text"/> | <input type="checkbox"/> | <input type="checkbox"/> |
| <input type="text"/> | <input type="text"/> | <input type="text"/> | <input type="text"/> | <input type="checkbox"/> | <input type="checkbox"/> |
| <input type="text"/> | <input type="text"/> | <input type="text"/> | <input type="text"/> | <input type="checkbox"/> | <input type="checkbox"/> |
| <input type="text"/> | <input type="text"/> | <input type="text"/> | <input type="text"/> | <input type="checkbox"/> | <input type="checkbox"/> |
| <input type="text"/> | <input type="text"/> | <input type="text"/> | <input type="text"/> | <input type="checkbox"/> | <input type="checkbox"/> |
| <input type="text"/> | <input type="text"/> | <input type="text"/> | <input type="text"/> | <input type="checkbox"/> | <input type="checkbox"/> |

User Timer

Cancel

OK

**System Mode**

System 1 | System 2

8000W Power  Grid Peak shaving

Use Export Controller  Priority Load

Solar Export

Limit to Load Only

100W Grid Trickle Feed

8000W Inverter Power Limiter

Cancel

OK

| System Mode |          |          |       |                                     |                          |
|-------------|----------|----------|-------|-------------------------------------|--------------------------|
| System 1    |          | System 2 |       |                                     |                          |
| Time Start  | Time End | Power    | SOC/V | Grid                                | Gen                      |
| 01:00       | 05:00    | 5000     | 80%   | <input checked="" type="checkbox"/> | <input type="checkbox"/> |
| 05:00       | 08:00    | 5000     | 40%   | <input type="checkbox"/>            | <input type="checkbox"/> |
| 08:00       | 10:00    | 5000     | 40%   | <input type="checkbox"/>            | <input type="checkbox"/> |
| 10:00       | 15:00    | 5000     | 80%   | <input type="checkbox"/>            | <input type="checkbox"/> |
| 15:00       | 18:00    | 5000     | 40%   | <input type="checkbox"/>            | <input type="checkbox"/> |
| 18:00       | 01:00    | 5000     | 35%   | <input type="checkbox"/>            | <input type="checkbox"/> |

User Timer

Cancel

OK

### Example:

During 01:00-05:00, when the battery SOC is lower than 80%, it will use the grid to charge the battery until the battery SOC reaches 80%.

During 05:00-08:00 and 08:00-10:00, when battery SOC is higher than 40%, the hybrid inverter will discharge the battery until the SOC reaches 40%.

During 10:00-15:00, when the battery SOC is higher than 80%, the hybrid inverter will discharge the battery until the SOC reaches 80%.

During 15:00-18:00, when the battery SOC is higher than 40%, the hybrid inverter will discharge the battery until the SOC reaches 40%.

During 18:00-01:00, when the battery SOC is higher than 35%, the hybrid inverter will discharge the battery until the SOC reaches 35%.

## Grid Supply Page

In the Settings menu, click on the GRID icon.

| Grid Setup  |   |
|---|---|
| Grid Type   | Connect IP F(W) V(W) V(Q) P(Q) P(F)   |
| Grid Mode   | General Standard 0/15   |
| Grid Frequency  | <input checked="" type="radio"/> 50Hz      Phase Type<br><input type="radio"/> 60Hz <input checked="" type="radio"/> 0/120/240<br><input type="radio"/> 0/240/120 |
| Grid Level  | LN:220V/LL:380V(AC)   |
| <input type="checkbox"/> IT system-neutral iis not grounded |   |

Cancel

OK

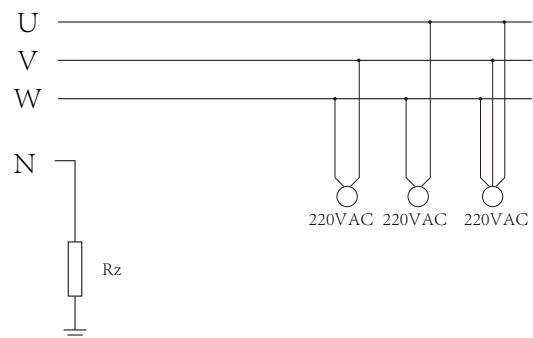

**Rz:** Large resistance ground resistor. Or the system doesn't have a Neutral line.

### What this page displays:

- Grid Mode:** General Standard - for example, EN50549\_CZ\_PPDS\_L16A, NRS097, G98/G99. Please follow your local grid code and choose the corresponding grid standard from the drop-down menu. If you cannot find your local grid standard from this menu, please manually input the grid settings as per instructions below.
  - G100** - Please ensure the inverter is set to G99/G100 for compliance to G100 regulations.
- Grid Level:** There are several voltage levels for the inverter output voltage in off-grid mode. LN:230VAC, LL:400VAC, LN:240VAC LL:420VAC, LN:120VAC, LL:208VAC, LN:133VAC, LL:230VAC.

- **IT system:** For the IT grid system, the Line voltage (between any two lines in a three-phase circuit) is 230Vac. If your grid system is an IT system, please enable “IT system” and tick the “Grid level” as 133-3P, as the picture above shows.

**Grid Setup**

Grid Type | Connect | IP | F(W) | V(W) | V(Q) | P(Q) | P(F)

Normal connect      Normal Ramp rate

Low frequency       High frequency

Low Voltage       High Voltage       **Cancel**

---

Reconnect after trip      Reconnect Ramp rate

Low frequency       High frequency

Low Voltage       High Voltage       **OK**

---

Reconnection Time       Power Factor

**What this page displays:**

- **Normal connect:** The allowed grid voltage/frequency range when the inverter first time connects to the grid.
- **Normal Ramp rate:** It is the startup power ramp.
- **Reconnect after trip:** The allowed grid voltage/frequency range for the inverter connects the grid after the inverter trip from the grid.
- **Reconnect Ramp rate:** It is the reconnection power ramp.
- **Reconnection time:** The waiting time period for the inverter to connect the grid again.
- **Power factor:** This is used to adjust the inverter's reactive power.

**Grid Setup**

Grid Type | Connect | IP | F(W) | V(W) | V(Q) | P(Q) | P(F)

Over voltage U.(10min. running mean)

HV3       HF3

HV2  --       HF2  --       **Cancel**

HV1  --       HF1  --

LV1  --       LF1  --       **OK**

LV2  --       LF2  --

LV3       LF3

**What this page displays:**

- **HV1:** Level 1 overvoltage protection point;
- **HV2:** Level 2 overvoltage protection point;
- **HV3:** Level 3 overvoltage protection point.
- **LV1:** Level 1 undervoltage protection point;
- **LV2:** Level 2 undervoltage protection point;
- **LV3:** Level 3 undervoltage protection point.
- **HF1:** Level 1 over frequency protection point;
- **HF2:** Level 2 over frequency protection point;
- **HF3:** Level 3 over frequency protection point.
- **LF1:** Level 1 under frequency protection point;
- **LF2:** Level 2 under frequency protection point;
- **LF3:** Level 3 under frequency protection point;
- **0.10s:** Trip time.



**Grid Setup**

Grid Type | Connect | IP | **F(W)** | V(W) | V(Q) | P(Q) | P(F)

F(W)

Over frequency: Droop f   
 Start freq f  Stop freq f   
 Start delay f  Stop delay f

Under frequency: Droop f   
 Start freq f  Stop freq f   
 Start delay f  Stop delay f

Buttons: Cancel, OK

**What this page displays:**

- **FW:** This series inverter is able to adjust inverter output power according to grid frequency.
- **Droop f:** The percentage of nominal power per Hz.

**For example:** “Start freq f>50.2Hz, Stop freq f<50.2, Droop f=40%PE/Hz” when the grid frequency reaches 50.2Hz, the inverter will decrease its active power at Droop f of 40%. And then, when the grid system frequency is less than 50.2Hz, the inverter will stop decreasing output power. For the detailed setup values, please follow the local grid code.

**Grid Setup**

Grid Type | Connect | IP | **F(W)** | **V(W)** | V(Q) | P(Q) | P(F)

V(W)       V(Q)

Lin: 20.0%      Lout: 5.0%

|    |                                     |    |                                   |    |                                     |    |                                   |
|----|-------------------------------------|----|-----------------------------------|----|-------------------------------------|----|-----------------------------------|
| V1 | <input type="text" value="109.0%"/> | P1 | <input type="text" value="100%"/> | V1 | <input type="text" value="90.0%"/>  | Q1 | <input type="text" value="44%"/>  |
| V2 | <input type="text" value="110.0%"/> | P2 | <input type="text" value="20%"/>  | V2 | <input type="text" value="95.7%"/>  | Q2 | <input type="text" value="0%"/>   |
| V3 | <input type="text" value="111.0%"/> | P3 | <input type="text" value="20%"/>  | V3 | <input type="text" value="104.3%"/> | Q3 | <input type="text" value="0%"/>   |
| V4 | <input type="text" value="111.0%"/> | P4 | <input type="text" value="20%"/>  | V4 | <input type="text" value="112.2%"/> | Q4 | <input type="text" value="-60%"/> |

Buttons: Cancel, OK

**What this page displays:**

- **V(W):** It adjusts the inverter active power according to the set grid voltage.
- **V(Q):** It adjusts the inverter reactive power according to the set grid voltage. This function adjusts inverter output (active and reactive) power when grid voltage changes.
- **Lock-in/Pn 5%:** When the inverter active power is less than 5% rated power, the VQ mode will not take effect.
- **Lock-out/Pn 20%:** If the inverter active power increases from 5% to 20% rated power, the VQ mode will take effect again.

**For example:** V2=110%, P2=20%. When the grid voltage reaches 110% times of rated grid voltage, the inverter output power will reduce its active output power to 20% rated power.

**For example:** V1=90%, Q1=44%. When the grid voltage reaches 90% times of the rated grid voltage, the inverter output power will output 44% reactive output power.

For the detailed setup values, please follow the local grid code.

**Grid Setup**

Grid Type | Connect | IP | F(W) | V(W) | V(Q) | P(Q) | P(F)

P(Q)       P(F)

Lin: 404.3%      Lout: 646.3%

P1: 0%    Q1: 0%    P1: 0%    F1: -2.400

P2: 0%    Q2: 0%    P2: 0%    F2: 0.000

P3: 0%    Q3: 0%    P3: 0%    F3: 0.000

P4: 0%    Q4: 0%    P4: 0%    F4: 6.000

Buttons: Cancel, OK

**What this page displays:**

- **P(Q):** It adjusts the inverter reactive power according to the set active power.
- **P(PF):** It adjusts the inverter PF according to the set active power.
- **Lock-in/Pn 50%:** When the inverter output active power is less than 50% rated power, it won't enter the P(PF) mode.
- **Lock-out/Pn 50%:** When the inverter output active power is higher than 50% rated power, it will enter the P(PF) mode.

For the detailed setup values, please follow the local grid code.



**NOTE:**

Only when the grid voltage is equal to or higher than 1.05 times the rated grid voltage will the P(PF) mode take effect.

## Paralleling Inverters Advanced Settings

To configure multi-inverter settings, click on the ADVANCE icon.

**ADVANCE**

Multi-Inverter | Others | Wind Turbine

Parallel     Master    Modbus SN:

Slave

**Warning: Before attempting to parallel a 3 Phase inverters please check that your model can be connected in a multi-inverter system.**

Buttons: Cancel, OK

**What this page displays:**

If the inverter operates as a master or a slave.

- **Modbus Device ID:** 'Modbus SN' that must be unique for each inverter connected to the bus/wire.

### What you can do from this page:

- Set the inverter as a master or slave per bus/wire.
- Set the phase in which the inverter will be paralleled.
- Set the Modbus SN for paralleling.

Each inverter will require a fuse isolator with surge protection and each group circuit will require an RCD. If the batteries are supplying power to the main load during the outage, then a change over switch will also be required or a split load can be used.

- The CT coils used to limit export power must only be connected to the master. Therefore, if six inverters are paralleled, three CT coils will be required.
- Connect a RJ45 communication cable between each inverter; the order is not important since both sockets are the same, so there is no IN or OUT.
- Each inverter must have a unique Modbus number.
- The maximum length of the communication cables is 2 meters (do not exceed this value).

**IMPORTANT:** When configuring inverters in parallel, it is important to first check firmware versions to be all the same on all inverters. It is strongly recommended to request firmware update on all inverters to the latest and the exact same firmware version.

**IMPORTANT:** All inverters in a parallel system must have their own isolating load breaker before it goes to the parallel breaker to ensure while programming that the load outputs are isolated from each other.

Only once confirmed all inverters are programmed correctly in parallel or three-phase then only the isolating breakers can be switched on, which then feeds to the main load output breaker where the actual parallel or three-phase connection is made that feeds the loads.



### NOTE:

The cables have two ends, one to be specifically connected to the BMS and another one to be connected to the inverter, do not change it. If the communication is not working correctly between inverters, then errors will appear on display. In this case, please check all settings and data cables.

- All inverters in a parallel system must have their own isolating load breaker before it goes to the parallel breaker to ensure while programming that the load outputs are isolated from each other.
- The grid input can also be connected in parallel.

If you need further help please refer to the Sunsynk website where you will find training videos and Frequently Asked Questions [www.sunsynk.com](http://www.sunsynk.com). Firmware prior installation is important to be updated and all inverters in parallel or three phase system must be the same.

Common questions that occur when paralleling inverters:

#### **Q1: What is the sequence to install/connect/commission?**

First of all, leave the main supplies off. Next, connect all communication cables, set up all LCDs and then, last of all, turn on the main supplies.

**Q2: What are the indications that the communication and the system are OK or not?**

Parallel errors will be shown as fault F46 on the display.

**Q3: What are the consequences of not setting one inverter in a parallel mode?**

It can damage the inverter.

**Q4: What are the consequences of having more than one Master Inverter or having no inverter set as 'Master'?**

It can damage the inverter. There are cases in which it is possible to have more than one master. For example, as aforementioned, six inverters paralleled in a three phase utility grid (three masters).

**Q5: What are the consequences for setting A, B, or C phases wrong while in parallel mode?**

It can damage the inverter. Recommend checking the phase rotation with a meter before switching on.

**Q6: What are the consequences of factory resetting, power cycling, or firmware updating one inverter in a parallel system?**

It can damage the inverter. Inverters needs to be isolated from each other before factory reset or firmware update.

**Q7: What consequences for changing ALL/ANY settings while operating in parallel mode?**

It can damage the inverter and fault F46 will be indicated on the display.

## Connecting the DRM's

This can be selected under advance settings.

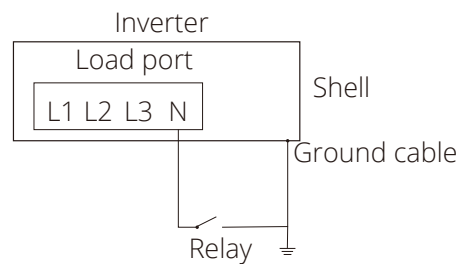
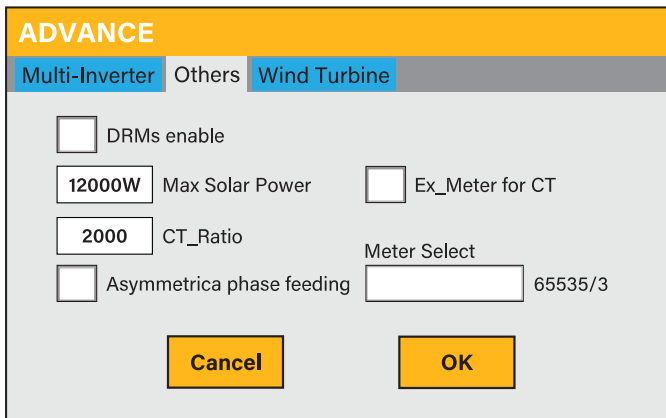

- **Ex\_Meter For CT:** When in a Three-phase system with a CHiNT Three-phase energy meter (DTSU666), click the corresponding phase where the hybrid inverter is connected. e.g. when the hybrid inverter output connects to A phase, please click A Phase.
- **Asymmetrica phase feeding:** If it was checked, the inverter will take power from the grid balance of on each phase (L1/L2/L3) when needed.
- Select the meter connection.

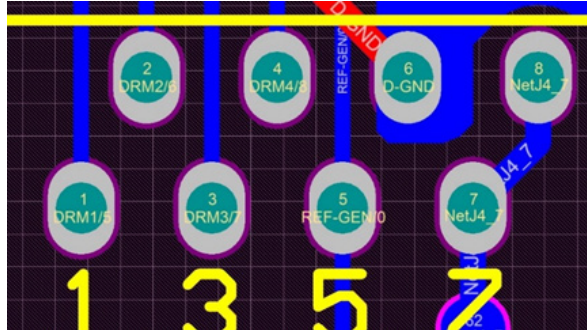
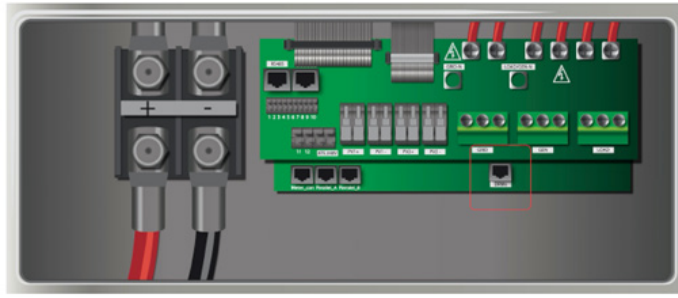

- |            |              |
|------------|--------------|
| 1. DRM 1/5 | 5. Ref 0     |
| 2. DRM 2/6 | 6. D Ground  |
| 3. DRM 3/7 | 7. Net J 4-7 |
| 4. DRM 4/8 | 8. Net J 4-7 |

## Solar Power Generated

This page shows the daily, monthly, yearly, and total solar power produced. Access this page by clicking on the 'Solar/Turbine' icon on the Home Page.

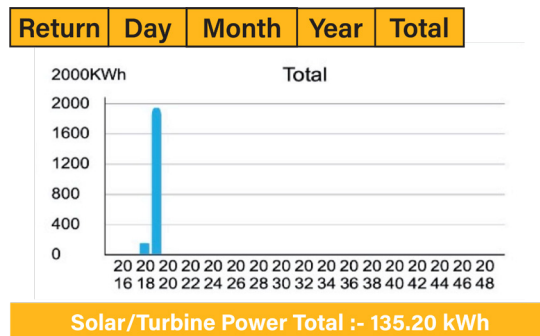
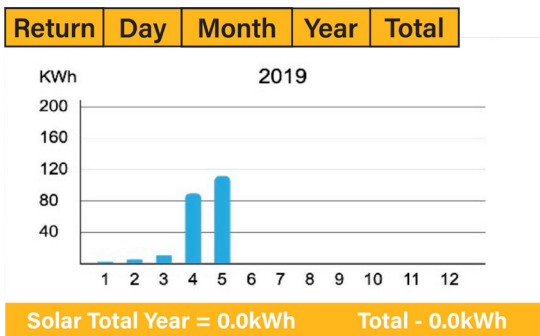
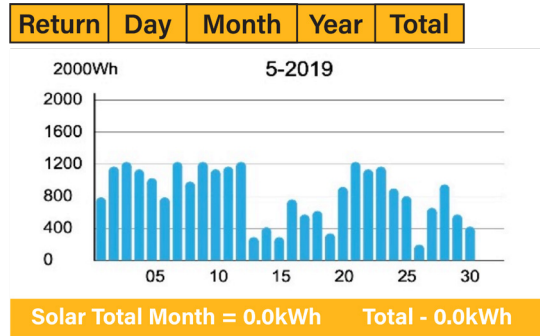
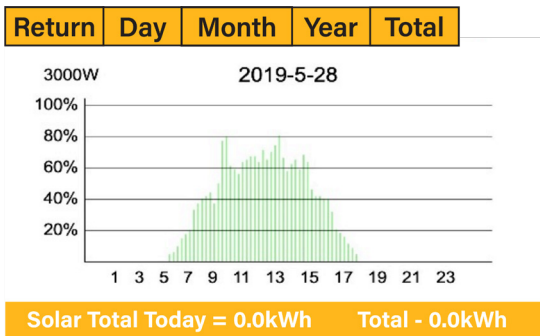



# Advanced Settings for Auxiliary Load

To configure Auxiliary Load (previously known as “smart load”) settings, click on the AUX LOAD icon.

## What this page displays:

- Use of the Gen (Aux) input or output.
- Generator peak shaving is ON or OFF.
- Peak Power Shaving value.

## What you can do from this page:

- Set up a generator input.
- Set up an auxiliary (smart) load.
- Switch on the generator and/or grid peak power saving and set the power shaving value.
- Use an additional inverter or micro inverter.

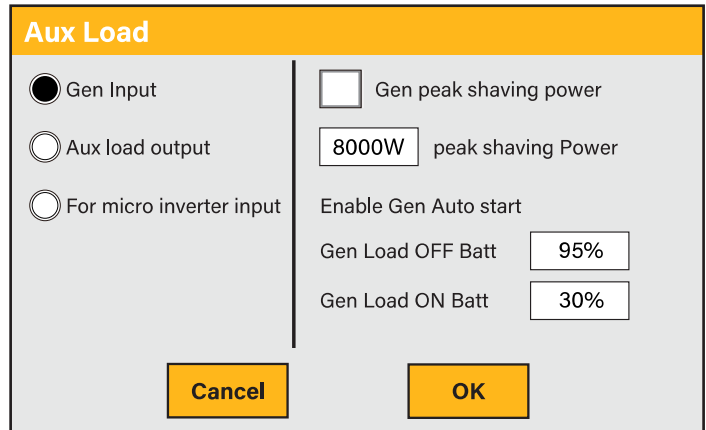

A nice feature of this page is that when the batteries are full and the inverter is still producing power from the solar PV or turbine, it is possible to direct the power generated to another load such as a water heater.

## For Gen Input mode:

- **Gen Input:** Tick this box if using a Generator. Allowed Max. power from diesel generator.
- **Peak shaving power:** This is a technique used to reduce electrical power consumption during periods of maximum demand on the utility grid. This enables the user to save substantial amounts of money due to the expensive peak power charges.
- **Gen Load OFF Batt:** Battery level when the Aux load switches off.
- **Gen Load ON Batt:** Battery level when the Aux load switches on.

## For Aux Load Output mode:

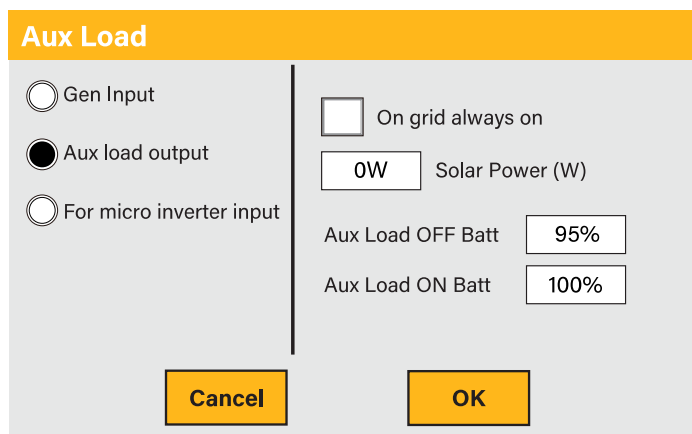

- **Aux Load Output:** This mode utilizes the Gen input connection as an output which only receives power when the battery SOC and PV power is above a user programmable threshold.

**For Example:** Power=500W, ON: 100%, OFF=95%. When the PV power exceeds 500W, and battery bank SOC reaches 100%, Smart Load Port will switch on automatically and power the load connected. When the battery bank SOC < 95% or PV power < 500w, the Smart Load Port will switch off automatically.

- **On Grid always on:** When click "on Grid always on" the smart load will switch on when the grid is present.
- **Solar Power:** Power limiter to the maximum power allowed to the Aux load.

- **Aux Load OFF Batt** Battery SOC at which the Smart load will switch off.
- **Aux Load ON Batt:** Battery SOC at which the Smart load will switch on. Also, the PV input power should exceed the setting value (Power) simultaneously and then the Smart load will switch on.

**For Micro Inverter Input mode:**

- **Micro Inverter Input:** To use the Generator input port as a micro-inverter on grid inverter input (AC coupled), this feature will also work with "Grid-Tied" inverters. Tick this box if intending to connect a supplementary inverter or micro inverter.
- **AC Couple OFF Batt:** When the battery SOC exceeds setting value, Microinverter or the grid-tied inverter will shut down.
- **AC Couple ON Batt:** If choosing "Micro Inv input", as the battery SOC reaches a gradually setting value (OFF), during the process, the microinverter output power will decrease linearly. When the battery SOC equals to the setting value (OFF), the system frequency will become the setting value (AC couple Frz high), and the Microinverter will stop working and stop exporting power produced by the microinverter to the grid.



**NOTE:**

Micro Inv Input OFF and On is valid for certain FW versions only.



# OPERATION MODES

## Mode I: Basic

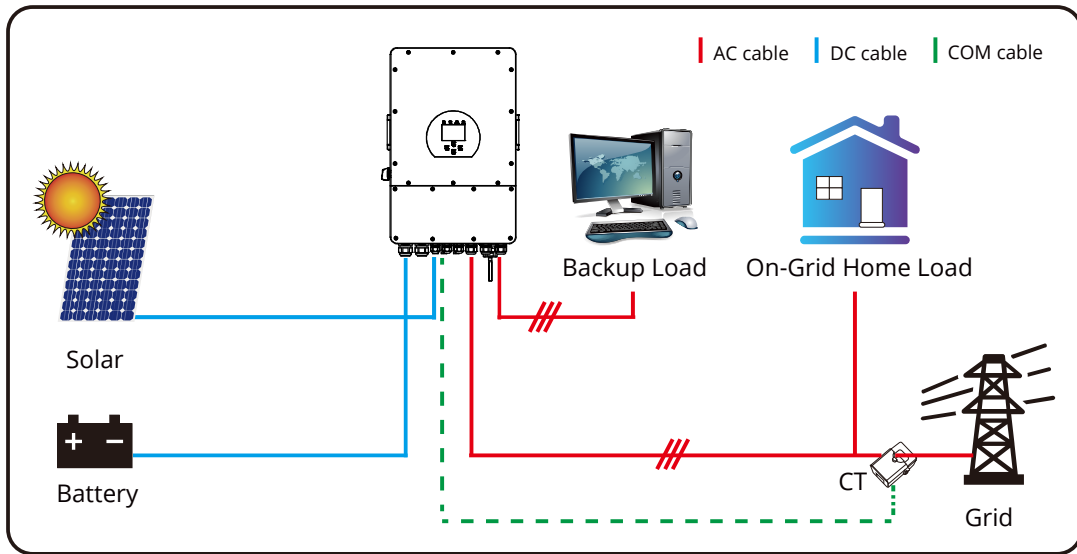

## Mode II: With Generator

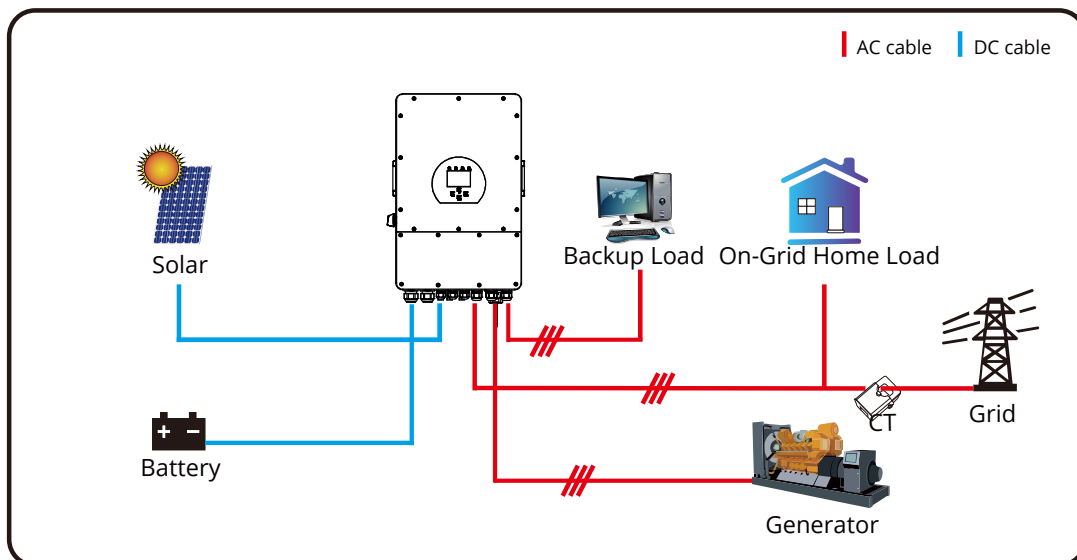

## Mode III: With Aux-Load

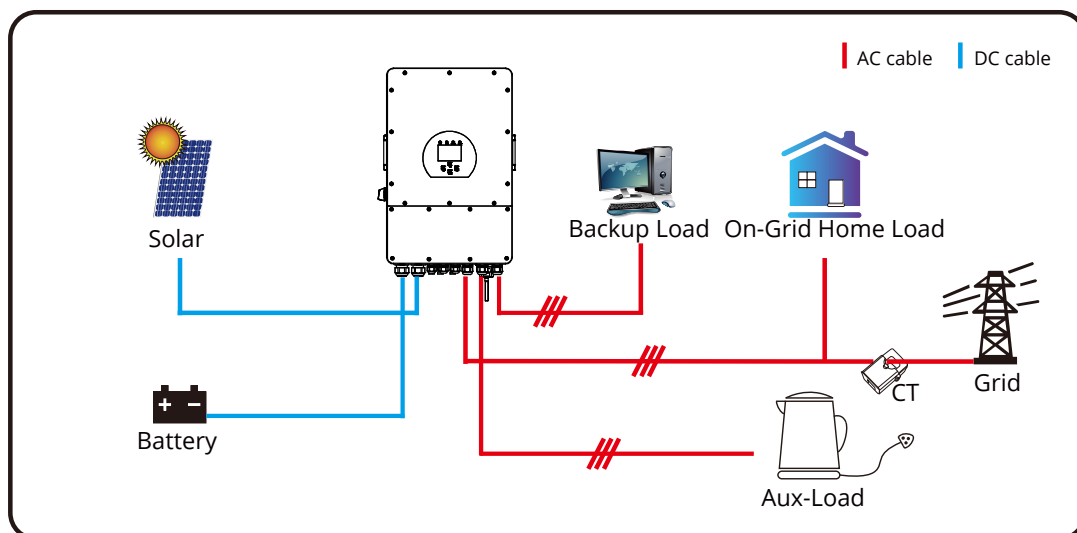

## Mode IV: AC Couple

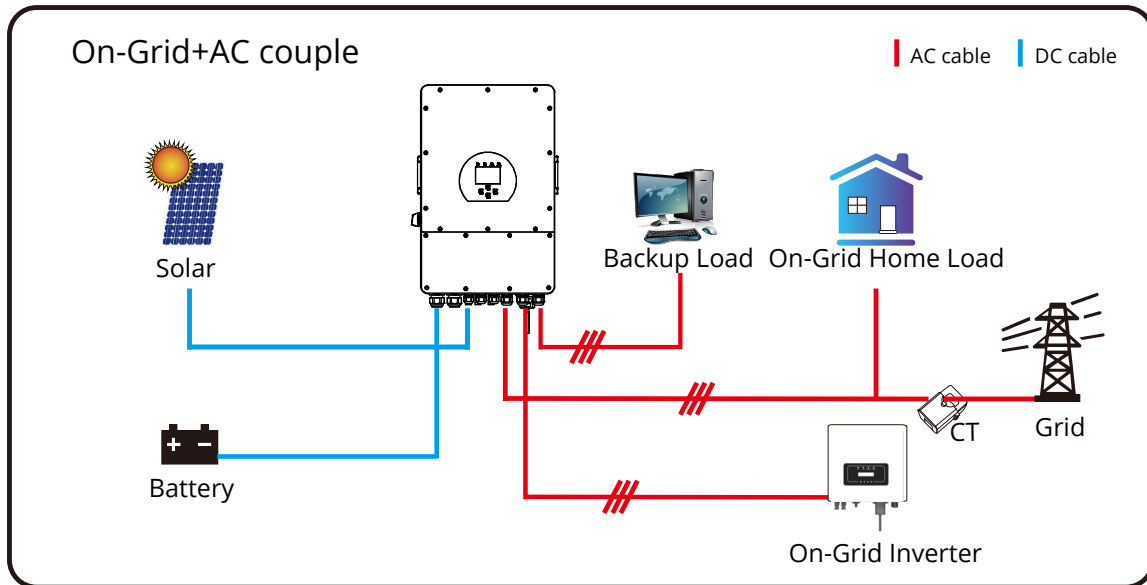

## Mode V: Grid-Tied

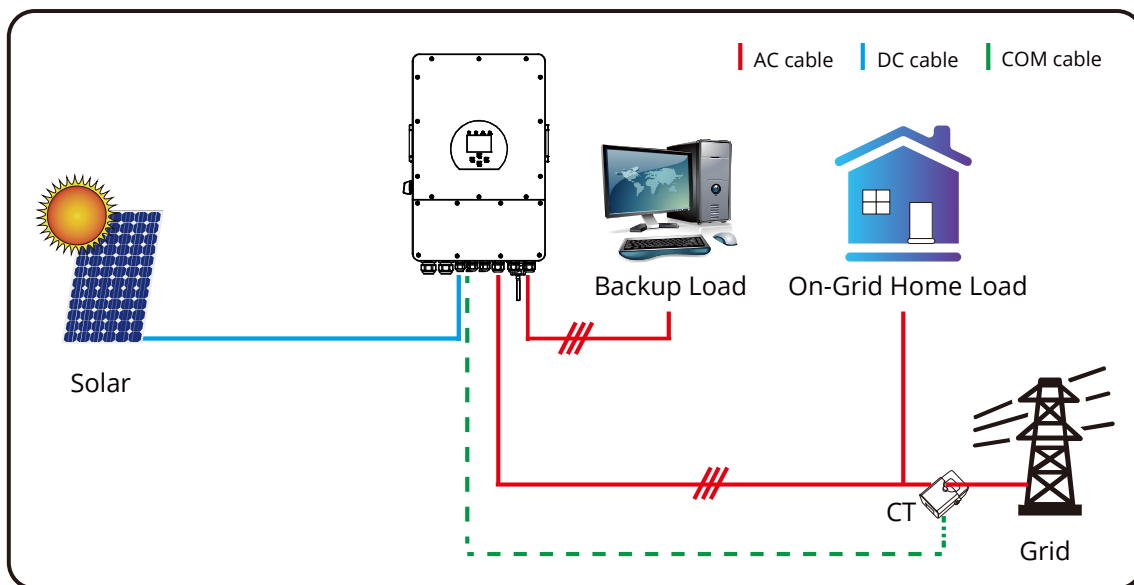

# FAULT CODES

To check the fault codes click on the FAULT CODES icon on the settings menu.

| FAULT CODES |                  |                  |
|-------------|------------------|------------------|
| Alarms Code | ID:2004244320    | Occured          |
| F56         | DC_VoltLow_Fault | 2022-01-26 12:45 |
| F56         | DC_VoltLow_Fault | 2022-01-24 11:00 |
| F56         | DC_VoltLow_Fault | 2022-01-07 18:19 |
| F56         | DC_VoltLow_Fault | 2022-01-08 01:58 |
| F56         | DC_VoltLow_Fault | 2021-11-09 13:22 |
| F56         | DC_VoltLow_Fault | 2021-11-03 17:48 |
| F56         | DC_VoltLow_Fault | 2021-10-27 16:31 |
| F56         | DC_VoltLow_Fault | 2021-10-20 19:17 |

If any of the fault messages listed in the following table appear on your inverter and the fault has not been removed after re-starting, please contact your local vendor or service centre. The following information is required:

1. Inverter serial number.
2. Distributor or service centre of the inverter.
3. On-grid Power Generation Date.
4. The problem description (including the fault code and indicator status displayed on the LCD) with as much detail as possible.
5. Owner's contact information.

In order to give you a clearer understanding of the inverter's fault information, we will list all possible fault codes and their descriptions when the inverter is not working properly.

| Error Code | Description         | Solutions  |
|------------|---------------------|--|
| F01        | DC_Inversed_Failure | <ol style="list-style-type: none"> <li>1. Check the PV input polarity.</li> <li>2. Seek help from us, if can not go back to normal state.</li> </ol>   |
| F07        | DC_START_Failure    | <ol style="list-style-type: none"> <li>1. The BUS voltage can't be built from PV or battery.</li> <li>2. Restart the inverter, if the fault existis, please contact us.</li> </ol>   |
| F13        | Working_Mode_Change | <ol style="list-style-type: none"> <li>1. When the grid type and frequency changed it will report F13;</li> <li>2. When the battery mode was changed to "No Battery" mode, it will report F13;</li> <li>3. For some old FW version, it will report F13 when the system work mode changed;</li> <li>4. Generally, it will desappear automatically when shows F13;</li> <li>5. If still same, and turn off the DC switch and AC switch and wait for one minute and then turn on the DC/AC switch;</li> <li>6. Seek help from Sunsynk.</li> </ol> |

| Error Code | Description             | Solutions  |
|------------|-------------------------|--|
| F15        | AC_OuverCurr_SW_Failure | AC side over current fault<br>1. Please check whether the backup load power and common load power are within the range;<br>2. Restart and check whether it is normal;<br>3. Seek help from Sunsynk.  |
| F16        | GFCI_Failure            | Leakage current fault<br>1. Check the PV side cable ground connection;<br>2. Restart the system 2-3 times;<br>3. If the fault still existing, please contact Sunsynk.  |
| F18        | Tz_Ac_Overcurr_Fault    | AC Slide over current fault.<br>1. Check if the backup load power is within the range of the inverter.<br>2. Restart, and check if it is normal.   |
| F20        | Tz_Dc_Overcurr_Fault    | DC side over current fault<br>1. Check PV module connect and battery connect;<br>2. When in the off-grid mode, the inverter startup with a big power load, and it may report F20. Please reduce the load power connected.;<br>3. Turn off the DC and AC switches, wait one minute, and then turn on the DC/AC switch again.<br>4. Seek help from us if you can not return to a normal state. |
| F21        | Tz_HV_Overcurr_fault    | BUS over current.<br>1. Check the PV input current and battery current settings;<br>2. Restart the system 2-3 times;<br>3. If the fault still existing, please contact Sunsynk.  |
| F22        | Tz_EmergStop_Fault      | Remotely shutdown<br>1. It tells the inverter is remotely controlled.  |
| F23        | Tz_GFCI_OC_Fault        | Leakage current fault<br>1. Check PV side cable ground connection;<br>2. Restart the system 2~3 times;<br>3. If the fault still exists, please contact us for help.  |
| F24        | DC_Insulation_Fault     | PV isolation resistance is too low<br>1. Check if the connection of PV panels and inverter are firmly connected.<br>2. Check if the earth bond cable on inverters is connected to the ground.  |
| F26        | BusUnbalance_Fault      | 1. Please wait for a while and check whether it is normal;<br>2. When the load power of 3 phases is big different, it will report the F26;<br>3. When there's DC leakage current, it will report F26;<br>4. Restart the system 2~3 times;<br>5. Seek help from us, if can not go back to normal state.   |

| Error Code | Description          | Solutions  |
|------------|----------------------|--|
| F29        | Parallel_Comm_Fault  | <ol style="list-style-type: none"> <li>1. When in parallel mode, check the parallel communication cable connection and hybrid communication address settings.</li> <li>2. During the parallel system startup period, inverters will report F29. When all inverters are in ON status, it will disappear automatically;</li> <li>3. If the fault exists, please contact us for help.</li> </ol>  |
| F34        | AC_Overload_Fault    | <ol style="list-style-type: none"> <li>1. Check the backup load connected, make sure it is in allowed power range;</li> <li>2. If the fault still exists, please contact up for help.</li> </ol>   |
| F41        | Parallel_system_Stop | <ol style="list-style-type: none"> <li>1. Check the hybrid inverter working status. If there's 1pcs hybrid inverter is in OFF status, the other hybrid inverters may report F41 fault in parallel system.</li> <li>2. If the fault exists, please contact us for help.</li> </ol>  |
| F42        | AC line low voltage  | <p>Grid voltage fault</p> <ol style="list-style-type: none"> <li>1. Check if the voltage is in the range of standard voltage in specification this can be adjusted via the grid set up page.</li> <li>2. Check if grid cables are correctly connected.</li> </ol>  |
| F46        | Backup Battery Fault | <ol style="list-style-type: none"> <li>1. Please check each battery status, such as voltage/SOC and parameters etc., and make sure all the parameters are same.</li> <li>2. If the fault still exists, please contact us for help.</li> </ol>  |
| F47        | AC_OverFreq_Fault    | <p>Grid frequency out of range</p> <ol style="list-style-type: none"> <li>1. Check the frequency is in the range of specification or not;</li> <li>2. Check whether AC cables are firmly and correctly connected;</li> <li>3. Seek help from us, if can not go back to normal state.</li> </ol>  |
| F48        | AC_UnderFreq_Fault   | <p>Grid frequency out of range</p> <ol style="list-style-type: none"> <li>1. Check the frequency is in the range of specification or not.</li> <li>2. Check whether AC cables are firmly and correctly connected.</li> <li>3. Seek help from us, if can not go back to normal state.</li> </ol>  |
| F55        | BAT1_VoltHigh_Fault  | <ol style="list-style-type: none"> <li>1. Check the battery 1 terminal voltage is high;</li> <li>2. Restart the inverter 2 times and restore the factory settings;</li> <li>3. Seek help from us, if can not go back to normal state.</li> </ol>   |
| F56        | BAT1_VoltLow_Fault   | <p>Battery low voltage</p> <ol style="list-style-type: none"> <li>1. Check if the battery voltage is too low.</li> <li>2. If the battery voltage is too low use the PV or grid to charge the battery.</li> <li>3. Check the battery BMS</li> </ol> <p>Important: Especially with Lithium batteries, ensure that the batteries Max. discharge current or power specification is the same or higher than the inverter specification.</p> |

| Error Code | Description                        | Solutions   |
|------------|------------------------------------|---|
| F58        | Battery_comm_Lose                  | <ol style="list-style-type: none"> <li>1. It tells the communication between hybrid inverter and battery BMS disconnected when “BMS_Err-Stop” is active.</li> <li>2. If don't want to see this happen, you can disable “BMS_Err-Stop” item on the LCD.</li> <li>3. If the fault still exists, please contact us for help</li> </ol> |
| F62        | DRMs0_stop                         | <ol style="list-style-type: none"> <li>1. The DRM function is for Australia market only.</li> <li>2. Check the DRM function is active or not.</li> <li>3. Seek help from us, if can not go back to normal state after restart the system.</li> </ol>  |
| F63        | ARC_Fault                          | <ol style="list-style-type: none"> <li>1. ARC fault detection is only for US market.</li> <li>2. Check PV module cable connection and clear the fault.</li> <li>3. Seek help from us, if can not go back to normal state.</li> </ol>  |
| F64        | Heat sink high-temperature failure | <p>Heat Sink temp is too high</p> <ol style="list-style-type: none"> <li>1. Check if the working environment temperature is too high.</li> <li>2. Turn off the inverter for 30 minutes and restart.</li> </ol>  |

| Fault Information | Instruction               | Fault Information | Instruction                  |
|-------------------|---------------------------|-------------------|------------------------------|
| F01               | DC_Inversed_Failure       | F33               | AC_OverCurr_Fault            |
| F02               | DC_Insulation_Failure     | F34               | AC_Overload_Fault            |
| F03               | GFDI_Failure              | F35               | AC_NoUtility_Fault           |
| F04               | GFDI_Ground_Failure       | F36               | AC_GridPhaseSeque_Fault      |
| F05               | EEPROM_Read_Failure       | F37               | AC_Volt_Unbalance_Fault      |
| F06               | EEPROM_Write_Failure      | F38               | AC_Curr_Unbalance_Fault      |
| F07               | GFDI_Fuse_Failure         | F39               | INT_AC_OverCurr_Fault        |
| F08               | GFDI_Relay_Failure        | F40               | INT_DC_OverCurr_Fault        |
| F09               | IGBT_Failure              | F41               | AC_WU_OverVolt_Fault         |
| F10               | AuxPowerBoard_Failure     | F42               | AC_WU_UnderVolt_Fault        |
| F11               | AC_MainContactor_Failure  | F43               | AC_VW_OverVolt_Fault         |
| F12               | AC_SlaveContactor_Failure | F44               | AC_VW_UnderVolt_Fault        |
| F13               | Working_Mode_change       | F45               | AC_UV_OverVolt_Fault         |
| F14               | DC_OverCurr_Failure       | F46               | AC_UV_UnderVolt_Fault        |
| F15               | AC_OverCurr_Failure       | F47               | AC_OverFreq_Fault            |
| F16               | GFCI_Failure              | F48               | AC_UnderFreq_Fault           |
| F17               | Tz_COM_OC_Fault           | F49               | AC_U_GridCurr_DcHigh_Fault   |
| F18               | Tz_Ac_OverCurr_Fault      | F50               | AC_V_GridCurr_DcHigh_Fault   |
| F19               | Tz_Integ_Fault            | F51               | AC_W_GridCurr_DcHigh_Fault   |
| F20               | Tz_Dc_OverCurr_Fault      | F52               | AC_A_InductCurr_DcHigh_Fault |
| F21               | Tz_GFDI_OC_Fault          | F53               | AC_B_InductCurr_DcHigh_Fault |
| F22               | Tz_EmergStop_Fault        | F54               | AC_C_InductCurr_DcHigh_Fault |
| F23               | Tz_GFCI_OC_Fault          | F55               | DC_VoltHigh_Fault            |
| F24               | DC_Insulation_Fault       | F56               | DC_VoltLow_Fault             |
| F25               | DC_Feedback_Fault         | F57               | AC_BackFeed_Fault            |

| Fault Information | Instruction             | Fault Information | Instruction                |
|-------------------|-------------------------|-------------------|----------------------------|
| F26               | BusUnbalance_Fault      | F58               | AC_U_GridCurr_High_Fault   |
| F27               | DC_Insulation_ISO_Fault | F59               | AC_V_GridCurr_High_Fault   |
| F28               | DCIOver_M1_Fault        | F60               | AC_W_GridCurr_High_Fault   |
| F29               | AC_AirSwitch_Fault      | F61               | AC_A_InductCurr_High_Fault |
| F30               | AC_MainContactor_Fault  | F62               | AC_B_InductCurr_High_Fault |
| F31               | AC_SlaveContactor_Fault | F63               | ARC_Fault                  |
| F32               | DCIOver_M2_Fault        | F64               | Heatsink_HighTemp_Fault    |



#### NOTE:

- The Three-Phase Hybrid Inverter is designed for grid-connected operation.
- The inverters meet the main standards concerning safety and electromagnetic compatibility. Before leaving the factory, all inverters undergo rigorous testing to ensure the inverter can operate reliably, as presented in Chapter 'Technical Specifications'.

If you need further help please refer to the Sunsynk website where you will find training videos and frequently asked questions [www.sunsynk.com](http://www.sunsynk.com).

## COMMISSIONING

### Start-Up / Shutdown Procedure

The inverter must be installed by a qualified / licensed electrical engineer in accordance with the country's wiring regulations.

Before switching on, the installation engineer must have completed the Earth Bond, RCD and earth leakage tests, checked that the solar panel Voc voltage does not exceed 480V and checked the battery voltage.

#### Power ON Sequence:







1. Switch on AC
2. Press Start Button
3. Switch on Battery and battery breaker
4. Switch on the DC (PV Isolator)

#### Shutdown Sequence:

1. Switch off AC
2. Press the start button
3. Switch off the battery and the battery breaker
4. Switch off the DC (PV isolator)

## Inverter Commissioning Info

After you have successfully powered up the inverter, it must be programmed and set up as per the programming feature above.

|   |  |  |  |
|---|--|--|--|
|    | Check each bond on the solar panels  | Check the VOC does not exceed 480V   | Ensure both MPPTs are balanced   |
|    | Measure the supply voltage check it matches the settings of the inverter                                       | If it falls out of the setting range it will cause the inverter shut down and alarm  | See Grid Setup page  |
|    | Check the battery charge and discharge is within the C rating of the battery. Too high will damage the battery |  | Check the battery BMS is communicating with the inverter   |
|   | This is the heart of the system this controller everything   | Ensure you are familiar with this, if you fully understand the controller you will fully appreciate the capabilities of there inverter                         | See section 'Program Charge / Discharge Times'   |
|  | This is for paralleling systems, and wind turbine  | If paralleling inverters in 3 Phase check you phase rotation before switching on the AC Load, in 3 Phase the output voltage will increase across phase to 400V | If using a wind turbine please ensure you have the correct limiting resistor, caps and rectifier |
|  | Familiarize yourself with common fault codes   |  |  |

## GDFI Fault

Before the inverter connects to the Grid, it will detect the impedance (effective resistance) of the solar PV + to Ground, and the impedance of the solar PV - to ground. If any of the impedance values are less than 33kΩ, the inverter will not connect to the Grid and will report an error F24 on its LCD.

## MAINTENANCE

The inverter is low maintenance. However, it is important that at least twice a year (for dusty environments this may need to be carried out weekly) all the cooling fans, air ducts are cleaned and dust free.

Check if there are no fault codes and Lithium battery communication is correct.

Weekly cleaning statement: Suggest micromesh filters as an available option, micro ants here are a real problem.



## APPENDIX A

The following table is the connection on **battery side** of SSLB1:

| Protocol | Description   |
|----------|---|
| CAN      | Pin 1: CAN-H<br>Pin 5: CAN-L<br>Pin 2, 3, 4, 6, 7, 8: NC  |
| RS485    | Pin 1: RS485B<br>Pin 2: RS485A<br>Pin 3, 6: GND<br>Pin 7: RS485A<br>Pin 8: RS485B<br>Pin 4, 5: NC                 |
| RS232    | Pin 3: BMS transmit; Computer receiver<br>Pin 4: BMS receiver; Computer transmit<br>Pin 5: GND<br>Pin 1, 2, 6: NC |

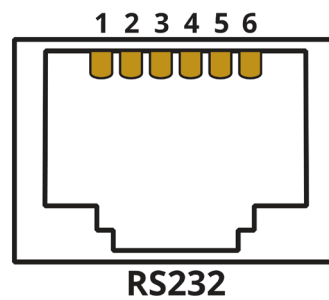
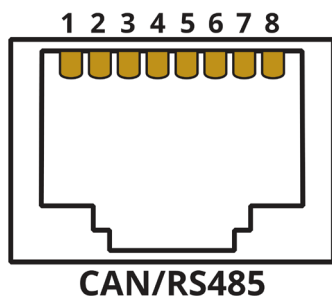

The following table is the connection on **inverter side**:

| Protocol | Description   |
|----------|---|
| CAN      | Pin 4: CAN-H<br>Pin 5: CAN-L<br>Pin 1, 2, 3, 6, 7, 8: NC  |
| RS485    | Pin 1: RS485B<br>Pin 2: RS485A<br>Pin 3, 6: GND<br>Pin 7: RS485A<br>Pin 8: RS485B<br>Pin 4, 5: NC                 |
| RS232    | Pin 3: BMS transmit; Computer receiver<br>Pin 4: BMS receiver; Computer transmit<br>Pin 5: GND<br>Pin 1, 2, 6: NC |

## APPENDIX B

---

Inverters sold in Australia will be set to the Default Australian standards.

## APPENDIX C

---

The Sunsynk Three-Phase Hybrid Inverter is compatible with the Sunsynk Connect app, via a Wi-Fi or GSM data logger (See Sunsynk Connect instruction manual).

## APPENDIX D

---

If an external Residual Current Device (RCD) is used it should be of Type A/AC with a tripping current of 30mA or higher.

### Use of RCDs

Residual Current Devices (RCDs): An RCD dedicated for an Inverter Energy System (IES) may be used to meet the mechanical cable protection requirements of AS/NZS3000 for the cable from the switchboard to the IES. If an RCD is installed the engineer must:

1. Disconnect all live conductors (including both active and neutral conductors).
2. Be of the type specified in the inverter manufacturer's instructions or as labelled on the inverter.

We recommend the use of an RCD on all circuits and sub-circuits connected to the Sunsynk Inverter. Below is the specifications for a Residual Current Breaker with Overcurrent Protection (RCBO).

| Earth-leakage protection class      | Type A        |
|-------------------------------------|---------------|
| Earth-leakage sensitivity           | 30mA          |
| Curve code                          | C             |
| Network type                        | AC            |
| Poles description                   | 2P            |
| Earth-leakage protection time delay | Instantaneous |

## APPENDIX E

---

The Sunsynk inverter can be connected to the internet, but you need to add a data logger to do this.

The inverter is compatible with Sunsynk Connect data-logger, which you can obtain from us with your distributor

1. LAN-Type Data Logger
2. Wi-Fi-Type Data Logger
3. GSM-Type Data Logger

To setup the Internet connection for the Sunsynk Connect, please refer to the App User instructions. The Data Logger should be connected to the bottom of the inverter via the connection socket marked WIFI.

For more information, training videos, software upgrades, help line, forum please refer to <http://www.sunsynk.com> - Tech Support (Do not forget to register first on the website).

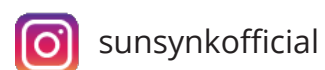



## CONTACT US

**Call us:** +44 151 832 4300 **Email us:** [sales@sunsynk.com](mailto:sales@sunsynk.com)

**HK Address:** Room 702-704, 7/F Texwood Plaza, 6 How Ming Street, Kwun Tong, Kowloon, Hong Kong.

**UK Address:** Sunsynk UK Ltd, 17 Turnstone Business Park, Mulberry Avenue, Widnes, Cheshire, WA8 0WN.

**SA Address:** Globaltech Sunsynk South Africa (Pty) Ltd, Unit 2 Highview Boulevard, Ferndale 2194.

**NL Address:** Sunsynk NL BV, Henri Wijnmalenweg 8, 5657 EP Eindhoven, Netherlands.

GlobalTech Ltd



Powered by  
SUN SYNK