

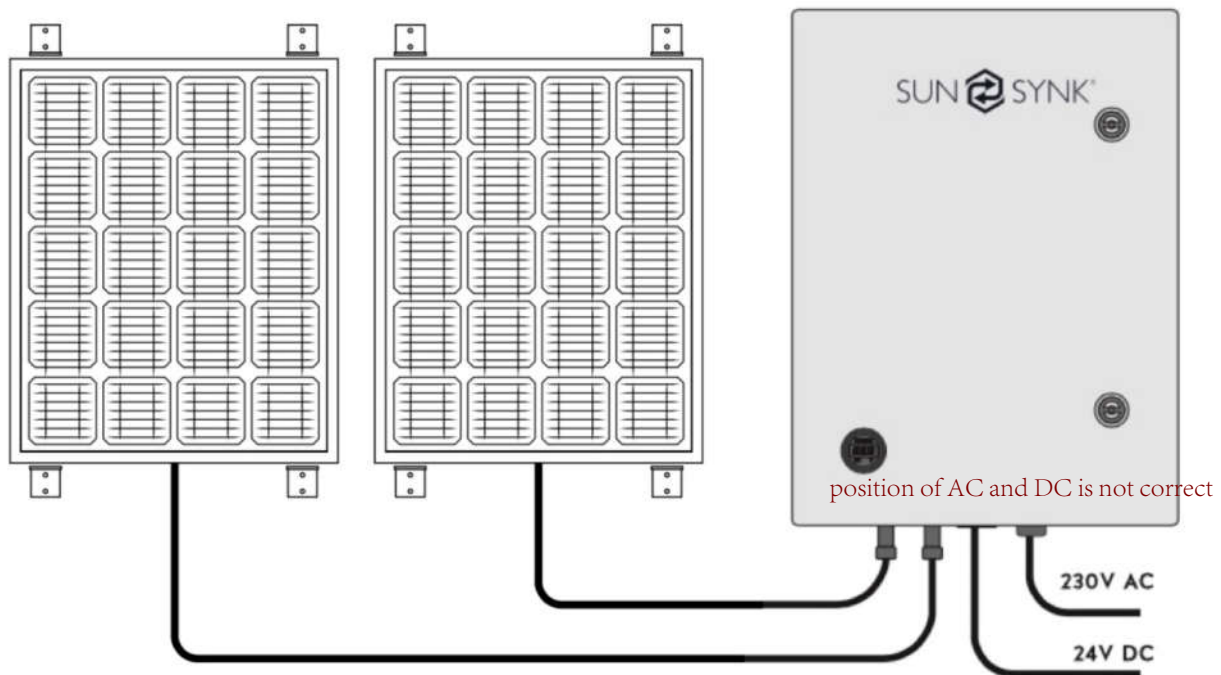

Power Bank 300 XL

300W Inverter with 300W MPPT Charge Controller and 1kWh
Lithium Battery Bank



USER MANUAL

Global Tech China Ltd, 3 Floor, Wai Yip Industrial Building.171 Wai Yip Street,
Kwun Tong, Kowloon, Hong Kong.

Tel: +852 2884 4318 Fax: +8522884 4816

www.sunsynk.com / sales@globaltech-china.com / www.globaltechhk.com

INDEX

1. INTRODUCTION	3
2. PB 300 XL COMPONENTS	4
3. APPLICATIONS	5
4. TECHNICAL SPECIFICATION	6
5. INSTALLATION.....	6
5.1. ASSEMBLING THE POWER BANK	6
5.2. MOUNTING THE SYSTEM	7
6. WIRING.....	8
6.1. THE AC THREE-WAY CONNECTOR:.....	8
7. OPERATION.....	9
7.1. SWITCHING ON	9
8. SAFETY INSTRUCTIONS	10
9. TROUBLESHOOTING	10

1. INTRODUCTION

The PB 300 XL is a unique storage device (a complete off-grid solution) that contains all the constituent parts of a solar power system within its weatherproof casing. The design is so simple that the user could quickly set up a simple solar power system to provide AC for devices with power up to 300 W.

In the casing, there is a charge controller, a storage bank of 2 x 443Wh lithium-ion batteries, a DC-to-AC inverter, and a logic program that manages the whole system. All that is visible on the outside is the cable that takes the DC power from the solar panels and AC power outlet.

It can run TVs, computers, lights, fans, and any other utility within its operating limits. ^{not correct} The unit can power a mixed load with power up to 300W and battery storage of 1000Wh. In addition to that, it is equipped with temperature control and overload protection, while a PCM card protects each battery card.

The PB 300 XL can operate at any time of the day and be set to 'automatic' mode, in which it operates only at night or when power is required. ^{no UPS function} It can either operate 24hrs or be set in the UPS mode, where it operates only at night or where power cuts out.

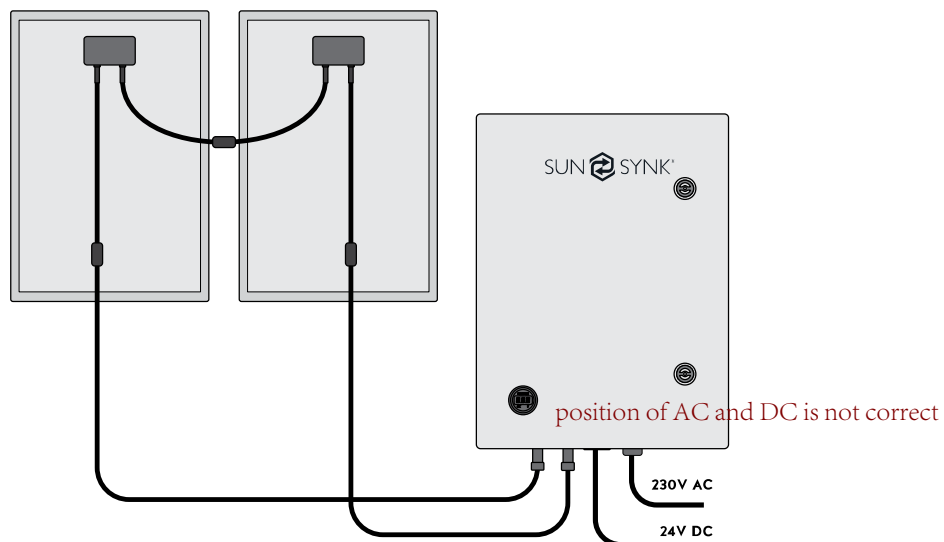

PB 300 XL has four terminals (left to right):

- 2 x Solar In;
- 1 x 24V DC Out;
- 1 x AC Out.

Also visible on the bottom, there is an air-intake and an outlet fan-grill.

For the power bank to function, it must have both solar panels plugged in.

2. PB 300 XL COMPONENTS

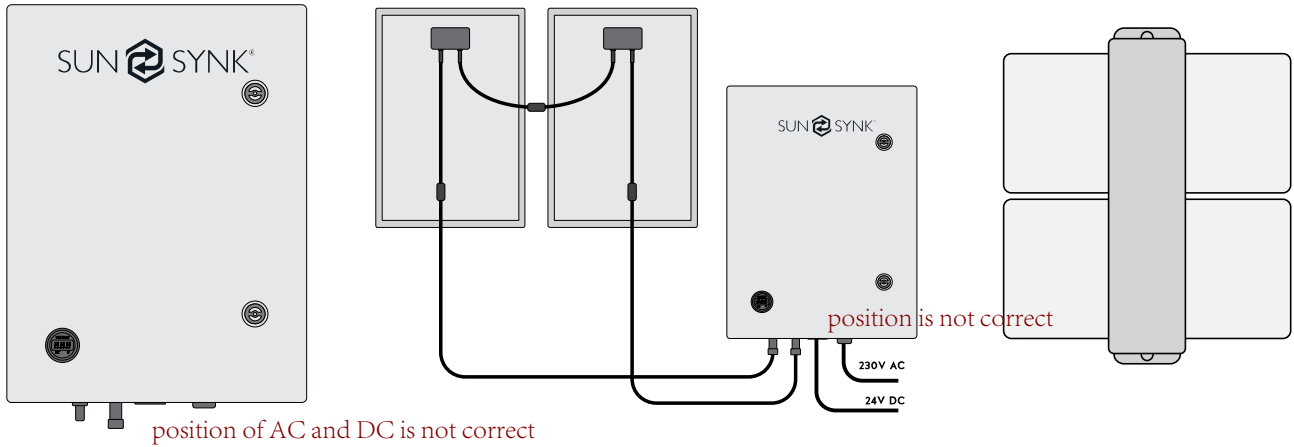

Power Bank 300 XL

2 x 125W Solar Panels & Fixings
2 x 100W

2 x Lithium Battery Packs
Total (1kWh)

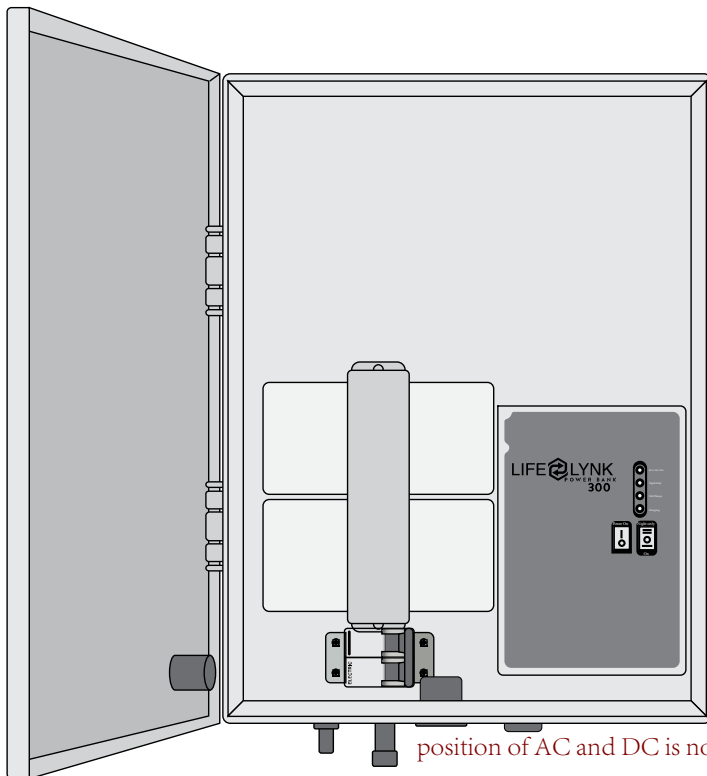

Also includes:

- Cables and connectors;
- 300W inverter 230V output;
- Lithium battery digital charge controller;
- Digital voltage meter;
- User resettable overload fuse;
- Built-in 300W MPPT charge controller;
- Solar Isolator Switch;
- Battery Isolator Switch.

3. APPLICATIONS

Potential Applications Include:

Street lighting - solar powered (storage device)

Billboard lighting - solar powered (storage device)

Computers/lighting/water pumps/fans

Ideal for developing countries needing off-grid power

Can be used on large marine vessels for uninterrupted power supply

Security Floodlighting (over 5 hours):

2 x 125W solar panels 2 x 100W

1 x PB 300 XL (1kWh)

5 x 20W LED security floodlights

Classroom Pack (over 4 hours)

2 x 125W solar panels 2 x 100W

1 x PB 300 XL(1kWh)

1 x multi-socket outlet (AC)

4 Laptop computers (50 W each), one internet router one printer (20W)

2 x LED lights (7W each)

Home Pack (over 6 hours)

2 x 125W solar panels 2 x 100W

1 x PB 300 XL(1kWh)

1 x multi socket outlet (AC)

1 x TV (40W)

1 x table fan (10W)

2 x LED lights (10W)

1 x water cooler (70W)

1 x smartphone charger

Recharging the batteries is around 5/6 hours in countries with sun radiance of over five sun hours.

4. TECHNICAL SPECIFICATION

Maximum Recommended PV Power	300W
Minimum PV Input Voltage	35V
Maximum PV Input Voltage	60V
Charge Controller Type	MPPT
Total Harmonic Distortion	MSW
Output Voltage	220VAC 230V
Output Power	300W
Output Frequency	50Hz
Connection Type	Sunsynk / MC4
Efficiency	Peak Efficiency > 90%
Product Size	46cm x 33cm x 13cm
Net Weight	13.5 kg
Operating Temperature	-20 to +50 °C
Weatherproof	IP 45 <i>this is not same as marked at carton box?</i>
Power Bank Material	Coated Mild Steel
Solar Panels	Pmax 125W 250W
Batteries	2 x 25.2V, 17.6Ah, lithium-ion cells, wire AWG 16 x Lmin 300 mm with shrinkable insulation tube
Minimum Wh of the Batteries Pack	443.52Wh
Approvals	CE, ROHS, MDS

5. INSTALLATION

5.1. Assembling the Power Bank

Take great care to place the packs into the casing without any damage to their out protection sleeve.

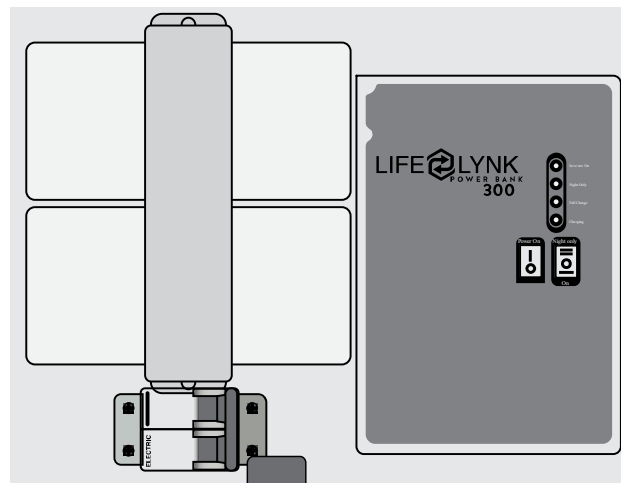
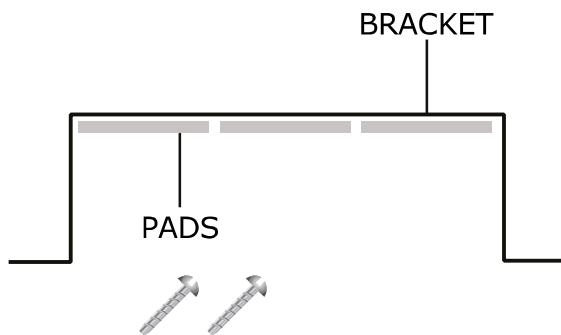

Position is not correct

The brackets are padded in the inside to prevent any damage caused by the metal to the battery sleeve.

There are two Phillips screws per bracket, and the holes in the mounting board are already threaded. Each battery pack comes with two sets of leads.

In the installation process, we are only concerned with the pair that is black and red.

Place the batteries sideways into the container with the leads heading towards the PCB, with the black leads secured out of the way.

The bracket should be placed over the batteries and secured in place by the two screws. The holes in the metal mounting board are clearly visible.

5.2. Mounting the System

1. Install the solar panels using the L brackets provided and connect the cables to the PB 300 XL.
2. Mount the PB 300 XL onto a non-flammable wall.

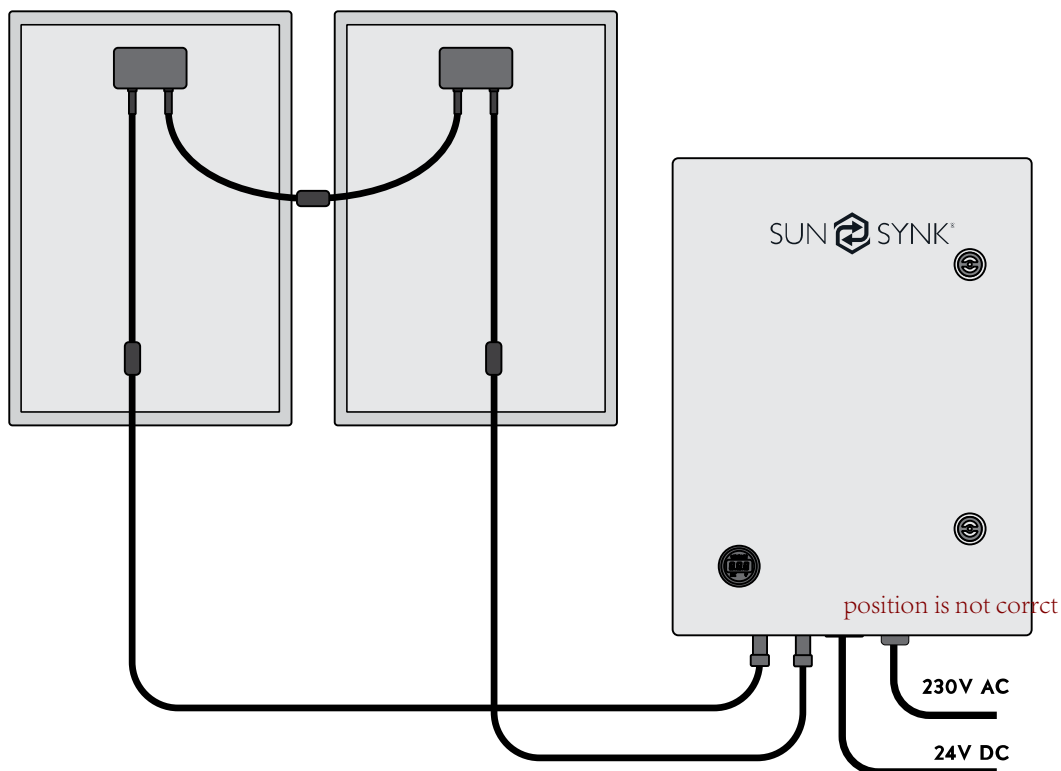

Solar panels can be installed either on the roof or the ground. When selecting the location to install solar panels, several conditions must be taken into account. We will address some technical considerations and details that you should pay attention to before choosing where to install your solar panels.

Orientation and Inclination:

If the place is located in the Northern hemisphere of the Earth, then the solar panels should face the South. On the other hand, areas located in the Southern Hemisphere of the planet must face North for maximum energy performance.

Shadings:

PV systems cannot work efficiently with an object that continually causes shades in the PV array; therefore, you must consider the presence of nearby trees, chimneys, antennas, or houses that could cause shade on your solar panels.

6. WIRING

When assembling a solar power system using the PB 300 XL, it is necessary to attach cables 3-way (AC) connectors and for the DC MC4 connectors are used. The following is an assembly instruction for both AC/DC connectors.

6.1. The AC three-way connector:

- a) Yellow/green – Earth
- b) Blue – Neutral
- c) Brown – Phase

The letters E, N, and L are engraved on the green connector.

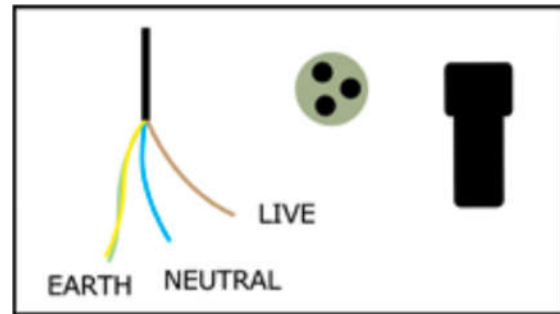

7. OPERATION

Switch Positions:

- Power ON – System live.
- Night Only – System OFF during the day and ON during the night.
- ON – System ON and ready to be used all the time.

LED Indicators:

- Inverter ON – System OK and powered ON.
- Night Only – System OFF during the day and ON during the night.
- Full Charge – Batteries are fully charged.
- Charging – Batteries are charging.

Buzzer Indicators:

- “Beep...beep...” – System overload indication.
- “Beep beep...beep beep...” – System low voltage indication.
- “Beep beep beep... beep beep beep” – System high voltage indication.
- “Beep beep beep beep...beep beep beep beep” – System high temperature indication.
- “Beep beep beep beep beep...beep beep beep beep beep” – System short-circuit indication.

Once the PB 300 XL has been fixed into a suitable location, solar panels wired, batteries connected, and AC wired to a fuse board or power block, it is time to turn on the device.

7.1. Switching On

The two switches are positioned at the bottom of the circuit board.

a) Left side switch (On Off) powers on the device

b) Right side switch ^I selected sets night only and when positioned in ^I sets 24 hours on. *not correct*
_{II}

The user must turn on the PB 300 XL and select whether it should operate for 12 hours or 24 hours. Then, the box cover should be closed and secured. The device will not require any further adjustment.

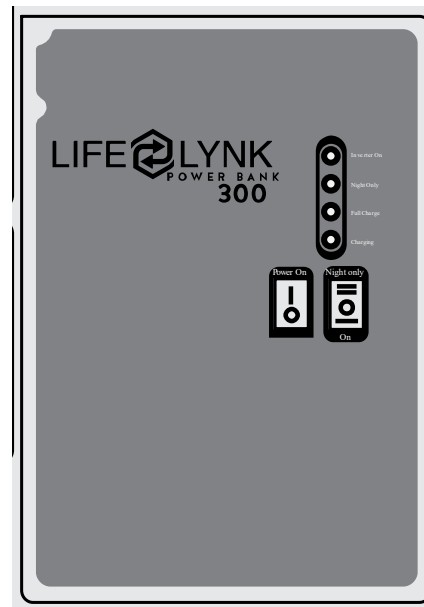

8. SAFETY INSTRUCTIONS

The PB 300 XL is an off-grid system, which means it cannot be connected to the supply grid.

The following instructions should, therefore, be read before any installation takes place:

1. DO NOT attach any part of the PB 300 XL or any system that it is part of, to mains grid supply.
2. When installing any system using the PB 300 XL, ensure a certified electrical engineer is present to check the system is assembled correctly and safely.
3. Although the PB 300 XL is built into a weatherproof box it is advisable to place a rain/sun shelter or awning over the top.
4. When installing the cabling between solar panels and the PB 300 XL, ensure the wiring is not connected to the panels until the circuit is assembled and complete.
5. The PB 300 XL should not be positioned near any flammable material or in any location which may accumulate flammable fumes or gases.
6. Make sure the vent holes and fan grill are not obstructed to prevent overheating.
7. Only use approved cabling when making a solar power system.
8. PB 300 XL is designed to use 2 x 443Wh lithium-ion battery packs. No other source of power should be used.
9. DO NOT immerse the PB 300 XL in water; it is not waterproof.

9. TROUBLESHOOTING

Once the Power Bank 300 XL is set up, there is very little to do. However, if there is no power coming out of the PB 300 XL (after 24hrs), please check the following.

- The switches are on and set to night only or 24 hrs.
- The wiring from the batteries is firmly connected to the main circuit board.
- The cabling coming from the solar panels is properly connected to the PB 300 XL via one of the two terminals.
- The solar panels are exposed to the sun for at least 6 hours a day.
- There is no obstruction to the solar panels blocking the sun's rays.
- OVERLOADING - If too many appliances are connected to the PB 300 XL, it will shut down.
- In that case, unplug those appliances and wait 5 minutes while the system resets itself. Then reattach a reduced number of appliances (reduce the load).



Global Tech China Ltd, 3 Floor, Wai Yip Industrial Building.171 Wai Yip Street,
Kwun Tong, Kowloon, Hong Kong.

Tel: +852 2884 4318 Fax: +8522884 4816

www.sunsynk.com / sales@globaltech-china.com / www.globaltechhk.com